

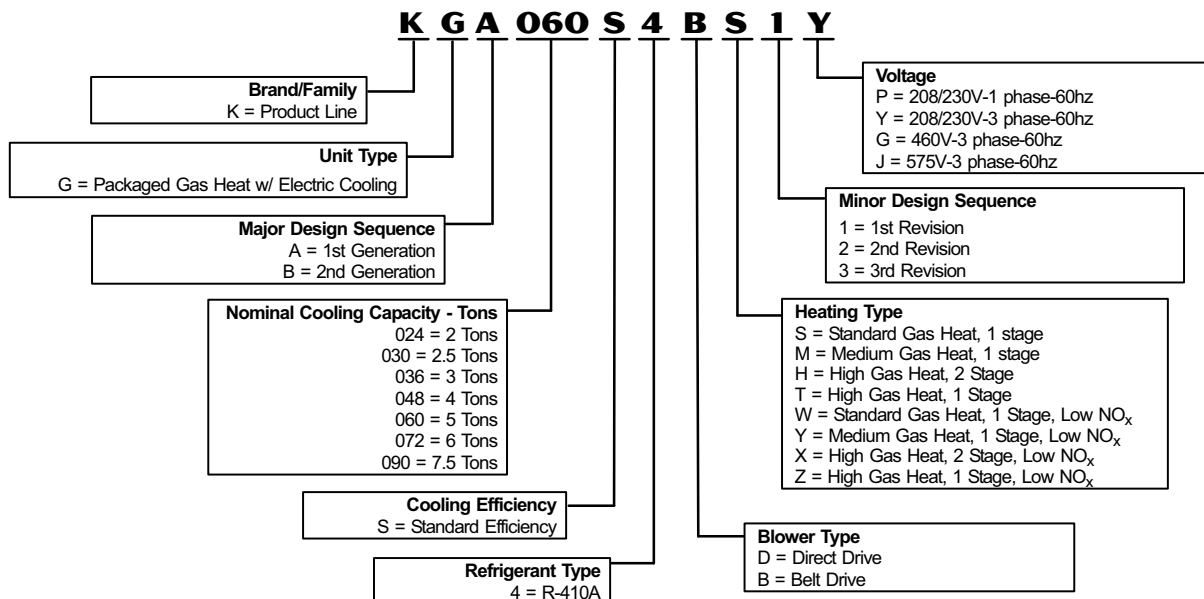

ASHRAE 90.1  
COMPLIANT

**2 to 7.5 Tons**  
**Net Cooling Capacity - 23,600 to 90,000 Btuh**  
**Gas Input Heat Capacity - 65,000 to 150,000 Btuh**

**MODEL NUMBER IDENTIFICATION**



## CONTENTS

Accessory Air Resistance .....	Page 25
Blower Performance .....	Pages 15 - 25
Cooling Ratings .....	Pages 13 - 14
Dimensions .....	Pages 32 - 39
Electrical Data .....	Pages 27 - 29
Features and Benefits .....	Pages 2 - 5
High Altitude Information .....	Page 12
Model Number Identification .....	Page 1
Options / Accessories .....	Pages 5 - 7
Specifications .....	Pages 10 -11
Sound Data .....	Page 27
Unit Clearances .....	Page 30
Weights .....	Page 31

## FEATURES AND BENEFITS

### APPROVALS

ETL and CSA listed.

Efficiency rating verified by GAMA (US) and CSA certified (Canada).

Components bonded for grounding to meet safety standards for servicing required by UL, ULC and National and Canadian Electrical Codes.

2 thru 5 ton models are certified in accordance with the USE certification program, which is based on AHRI Standard 210/240-2006.

6 and 7.5 ton models are certified in accordance with the ULE certification program, which is based on AHRI Standard 340/360-2007.

All models are ASHRAE 90.1 compliant. All Low NOx models meet the California Nitrogen Oxides (NOx) Standards that apply in the South Coast Air Quality Management District and the San Francisco Bay Area Air Quality Management District.

### WARRANTY

Limited ten years aluminized heat exchanger, limited fifteen years optional stainless steel heat exchanger.

Limited five years on compressors.

Limited one year all other covered components.

### CABINET

#### 1 Construction

Heavy-gauge steel panels and full perimeter heavy-gauge galvanized steel base rail provides structural integrity for transportation, handling, and installation.

Base rails have rigging holes. Three sides of the base rail have fork slots.

Raised edges around duct and power entry openings in the bottom of the unit provide additional protection against water entering the building.

#### Air-Flow Choice

Units are shipped in downflow (vertical) configuration, can be field converted to horizontal air flow configuration without the need of a kit.

#### 2 Power/Gas Entry

Electrical and gas lines can be brought through the unit base or through horizontal access knock-outs. Optional Bottom Gas Entry Kit is available.

#### 3 Exterior Panels

Constructed of heavy-gauge, galvanized steel with a two-layer enamel paint finish.

#### 4 Insulation

All panels adjacent to conditioned air are fully insulated with non-hygroscopic fiberglass insulation.

Unit base is fully insulated. The insulation also serves as an air seal to the roof curb, eliminating the need to add a seal during installation.

#### Access Panels

Access panels are provided for the economizer/filter section, heating/blower section, and the compressor/controls section.

### OPTIONS/ACCESSORIES

#### Factory Installed

##### Corrosion Protection

A completely flexible immersed coating with an electro-deposited dry film process. (AST ElectroFin E-Coat) Meets Mil Spec MIL-P-53084, ASTM B117 Standard Method Salt Spray Testing, ASTM 1153 Standard Specification for Methyl Isobutyl Ketone.

#### 5 Hinged Access Panels

Large access panels are hinged and have quarter-turn latches for quick and easy access to maintenance areas (economizer / filter, compressor / controls, heating / blower).

#### Field Installed

##### Coil Guards

Painted, galvanized steel wire guards to protect outdoor coil. Not used with Hail Guards.

##### Hail Guards

Constructed of heavy gauge steel, painted to match cabinet, helps protect outdoor coils from hail damage. Not used with Coil Guards.

##### Bottom Gas Entry Kit

Field installed piping kit to facilitate bottom gas entry.

## FEATURES AND BENEFITS

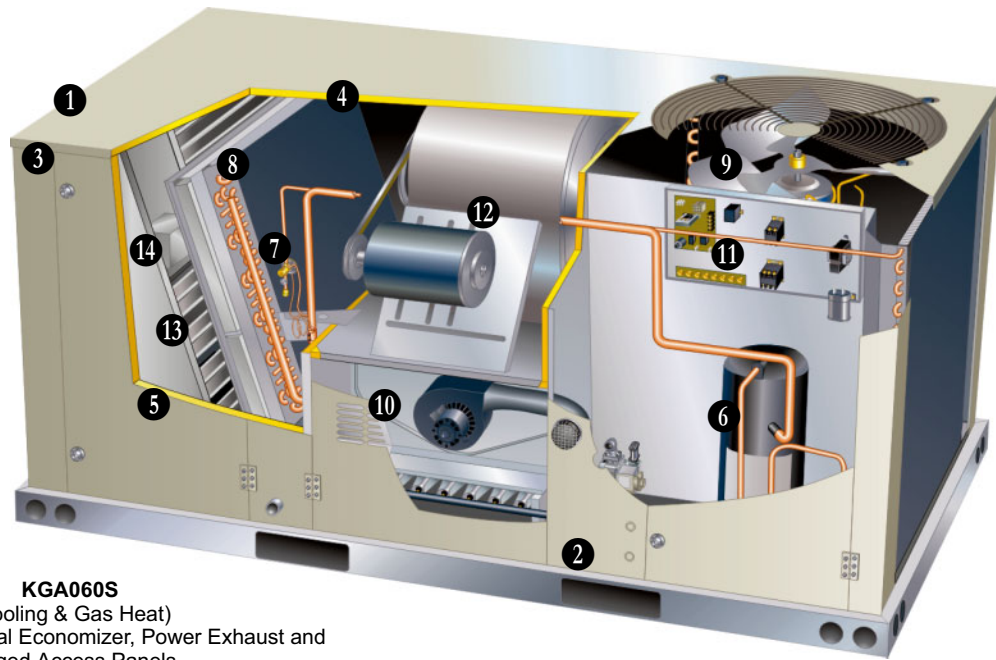

### KGA060S

(Cooling & Gas Heat)

Shown With Optional Economizer, Power Exhaust and Hinged Access Panels

### COOLING SYSTEM

Designed to maximize sensible and latent cooling performance at design conditions.

System can operate from 30°F to 125°F without any additional controls.

#### 6 Compressor

Resiliently mounted on rubber grommets for quiet operation. Scroll compressors for high performance, reliability and quiet operation.

#### Refrigerant

Non-chlorine, ozone friendly, R-410A. Unit is factory pre-charged with refrigerant. See Specifications Tables.

#### Compressor Crankcase Heater (Furnished on 072-090 Models Only)

Protects against refrigerant migration that can occur during low ambient operation.

#### 7 Thermal Expansion Valve

Assures optimal performance throughout the application range. Removable element head.

#### High Pressure Switch

Protects the compressor from overload conditions such as dirty condenser coils, blocked refrigerant flow, or loss of outdoor fan operation.

#### Filter/Drier

High capacity filter/drier protects the system from dirt and moisture.

#### Freezestat

Protects the evaporator coil from damaging ice build-up due to conditions such as low/no air flow, or low refrigerant charge.

#### 8 Coil Construction

Copper tube construction, enhanced rippled-edge aluminum fins, flared shoulder tubing connections, silver soldered construction for improved heat transfer. Factory leak tested.

#### Evaporator Coil

Cross row circuiting with rifled copper tubing optimizes both sensible and latent cooling capacity.

#### Condenser Coil

Two independent formed coils allow separation for cleaning.

#### Condensate Drain Pan

Plastic pan, sloped to meet drainage requirements of ASHRAE 62.1. Side or bottom drain connections. Reversible to allow connection at back of unit.

#### 9 Outdoor Coil Fan Motor

Thermal overload protected, totally enclosed, permanently lubricated sleeve (024, 030, 036 and 048 models) or ball bearings (060, 072 and 090 models), shaft up, wire basket mount.

#### Outdoor Coil Fan

PVC coated fan guard furnished.

### REQUIRED SELECTIONS

#### Cooling Capacity

Specify nominal cooling capacity of the unit.

### OPTIONS/ACCESSORIES

#### Field Installed

#### Condensate Drain Trap

Field installed only. Available in copper or PVC.

#### Compressor Crankcase Heater (Optional for 024-060 Models Only)

Protects against refrigerant migration that can occur during low ambient operation.

#### Low Ambient Kit

Cycles the outdoor fan while allowing compressor operation in the cooling cycle. This intermittent fan operation allows the system to operate without icing the evaporator coil and losing capacity. Designed for use in ambient temperatures no lower than 0°F. A crankcase heater must be installed on the compressor.

## FEATURES AND BENEFITS

### HEATING SYSTEM

- 10 Aluminized steel inshot burners, direct spark ignition, electronic flame sensor, combustion air inducer, redundant automatic single or dual stage gas valve with manual shut-off.

#### Heat Exchanger

Tubular construction, aluminized steel, life cycle tested.

Stainless Steel Heat Exchanger is required if mixed air temperature is below 45°F.

- 11 **Electronic Pilot Ignition**

Solid-state electronic spark igniter provides positive direct ignition of burners on each operating cycle. The system permits main gas valve to stay open only when the burners are proven to be lit. Should a loss of flame occur, the gas valve closes, shutting off the gas to the burners. Ignition module has LED to indicate status and aid in troubleshooting.

Watchguard circuit on module automatically resets ignition controls after one hour of continuous thermostat demand after unit lockout, eliminating nuisance service calls. Ignition control is factory installed in the controls section.

#### Limit Controls

Factory installed, redundant limit controls with fixed temperature setting. Heat limit controls protect heat exchanger and other components from overheating.

#### Safety Switches

Flame roll-out switch, flame sensor and combustion air inducer proving switch protect system operation.

#### Low NO<sub>x</sub> Models

All models are available in low NO<sub>x</sub> versions.

### REQUIRED SELECTIONS

#### Gas Input Choice - Order one:

- 65,000 Btuh Standard Gas Heat, 1 Stage (Not available for 090 models)
- 105,000 Btuh Medium Gas Heat, 1 Stage
- 105,000/150,000 Btuh High Gas Heat, 2 Stage
- 150,000 Btuh High Gas Heat, 1 Stage

#### Standard or Low NO<sub>x</sub>

Specify standard gas heat or Low NO<sub>x</sub> option.

### OPTIONS/ACCESSORIES

#### Factory Installed

##### Stainless Steel Heat Exchanger

Required if mixed air temperature is below 45°F.

#### Field Installed

##### Combustion Air Intake Extensions

Recommended for use with existing flue extension kits in areas where high snow areas can block intake air.

##### Low Temperature Vestibule Heater

Electric heater automatically controls minimum temperature in gas burner compartment when temperature is below -40°F. C.S.A. certified to allow operation of unit down to -60°F.

##### LPG/Propane Kits

Conversion kit to field change over units from Natural Gas to LPG/Propane.

##### Vertical Vent Extension Kit

Use to exhaust flue gases vertically above unit. Required when unit vent is too close to fresh air intakes per building codes. The vent kit also prevents ice formation on intake louvers.

### CONTROLS

#### UNIT CONTROL

All control voltage is provided via a 24V (secondary) transformer with built-in circuit breaker protection.

**Heat/Cool Staging** - Capable of up to 2 heat / 2 cool staging with a third party DDC control system or thermostat.

**Low Voltage Terminal Block** - Provides screw terminal connections for thermostat or controller wiring.

**Night Setback Mode** - Saves energy by closing outdoor air dampers and operating supply fan on thermostat demand only.

### OPTIONS / ACCESSORIES

#### Field Installed

##### Dirty Filter Switch

Senses static pressure increase indicating dirty filter condition.

##### Smoke Detector

Photoelectric type, installed in supply or return air section.

### 12 BLOWER

A wide selection of supply air blower options are available to meet a variety of air flow requirements.

#### Motor

Overload protected, equipped with ball bearings (belt drive) or sleeve bearings (direct drive).

Direct drive motors are offered on 024, 030, 036, 048 and 060 models.

Belt drive motors are offered on 036, 048, 060, 072 and 090 models and are available in several different sizes to maximize air performance.

#### Supply Air Blower

Forward curved blades, blower wheel is statically and dynamically balanced.

All belt drive motors have adjustable pulley for speed change.

#### Ordering Information

Specify direct drive or belt drive motor. For belt drive, specify motor horsepower and drive kit number when base unit is ordered.

### REQUIRED SELECTIONS

#### Supply Air Blower

Order one, belt drive or direct drive (See Blower Data Table for specifications).

Order one drive kit, belt drive only, see Drive Kit Specifications Table.

### INDOOR AIR QUALITY

#### Air Filters

Disposable 2 inch filters furnished as standard.

### OPTIONS/ACCESSORIES

#### Field Installed

##### Healthy Climate® UVC Germicidal Lamps

Helps eliminate mold and bacterial growth on the evaporator and drain pans. Improves indoor air quality and maintains efficiency of system by reducing fouling of evaporator coil.

##### Indoor Air Quality (CO<sub>2</sub>) Sensor

Monitors CO<sub>2</sub> levels adjusts economizer dampers as needed for Demand Control Ventilation.

### ELECTRICAL

### REQUIRED SELECTIONS

#### Voltage Choice

Specify when ordering base unit.

### OPTIONS/ACCESSORIES

#### Factory or Field Installed

##### Disconnect Switch (80 Amp)

Accessible from outside of unit, spring loaded weatherproof cover furnished. Main power to the unit is field connected to the disconnect which allows all power to be shut off for service. See Electrical tables for ordering information, Pages 27-29.

##### GFI Service Outlets (2)

115v ground fault circuit interrupter (GFCI) type.

## FEATURES AND BENEFITS

### **SERVICEABILITY**

Designed to streamline general maintenance and decrease troubleshooting time.

#### **Marked & Color-Coded Wiring**

All electrical wiring is color-coded and marked to identify which components it is connecting.

#### **Electrical Plugs**

Positive connection electrical plugs are used to connect common accessories or maintenance parts for easy removal or installation.

#### **Blower Access**

Supply air blower parts are located near the access door for easy servicing and adjustment.

#### **Thermal Expansion Valves**

Thermal expansion valves are located near the perimeter of the unit for easier access.

Removable element head allows change out of element and bulb without removing the TXV.

#### **Coil Cleaning**

Independently formed condenser coils allow separation for easier cleaning.

#### **Compressor Compartment**

Compressor is located near the perimeter of the unit for easier access. Compressor is isolated from the condenser air flow allowing system operation checks to be done without changing the air flow across the outdoor coils.

## OPTIONS / ACCESSORIES

### **ECONOMIZER/OUTDOOR AIR/EXHAUST OPTIONS**

#### **Factory or Field Installed**

##### **13 Economizer, Downflow**

Parallel gear-driven action return air and outdoor air dampers, plug-in connections to unit, nylon bearings, neoprene seals, 24-volt, fully-modulating, spring return motor, adjustable minimum damper position. Economizer includes barometric relief dampers.

Barometric Relief Dampers allow relief of excess air, aluminum blade dampers prevent blow back and outdoor air infiltration during off cycle, bird screen furnished. Hood furnished.

Outdoor Air Hoods are included when economizer is factory installed and are furnished with economizer when ordered for field installation.

Choice of single (factory installed) or differential (optional) enthalpy or temperature economizer control is available.

Horizontal conversion kit available for field installation.

#### **Single Enthalpy Control**

Outdoor air enthalpy sensor enables economizer if the outdoor enthalpy is less than the setpoint of the board. Furnished with Economizer.

#### **Field Installed**

##### **Outdoor Air Damper - Manual**

Two sliding dampers provide 0 to 35% outdoor air, installs internal to unit. Includes Outdoor Air Hood.

##### **Outdoor Air Damper Motorized Kit**

Used to convert Manual Outdoor Air Dampers to motorized dampers. Kit includes linked mechanical dampers and spring return damper motor with plug-in connection.

#### **Differential Enthalpy Control**

An optional, return air, solid-state enthalpy sensor can be ordered extra for field installation. Allows the economizer control board to select between outdoor air or return air, whichever has lower enthalpy. Field installed.

#### **Economizer Temperature Control - Single**

An optional, solid-state temperature sensor can be ordered extra for field installation. Enables the economizer when the outdoor air temperature is below the configured setpoint.

#### **Economizer Temperature Control - Differential**

Order two, single-temperature control kits. One is field installed in the return air section, the other in the outdoor air section. Allows the economizer control board to select between outdoor air or return air, whichever has lower temperature.

#### **Horizontal Conversion Kit**

Insulated panel covers the bottom return air opening on the unit base to convert downflow economizer to horizontal air flow.

##### **14 Power Exhaust Fan**

Installs internal to unit for down-flow applications only with economizer option. Provides exhaust air pressure relief. Interlocked to run when supply air blower is operating, fan runs when outdoor air dampers are 50% open (adjustable), motor is overload protected. Requires Economizer with Outdoor Air Hood. Fan is 16 in. diameter with 4 fan blades (T1PWRE10A) or 20 in. diameter with 5 blades (T1PWRE10N). Both include a 3/4 hp motor.

NOTE - Not available for 024 and 030 models.

### **CEILING DIFFUSERS**

#### **Ceiling Diffusers (Flush and Step-Down)**

Aluminum grilles, large center grille, insulated diffuser box with flanges, hanging rings furnished, interior transition (even air flow), internally sealed (prevents recirculation), adapts to T-bar ceiling grids or plaster ceilings.

#### **Transitions (Supply and Return)**

Used with diffusers, installs in roof curb, galvanized steel construction, flanges furnished for duct connection to diffusers, fully insulated.

### **ROOF CURB**

#### **Roof Curb, Downflow**

Nailer strip furnished, mates to unit, US National Roofing Contractors Approved, shipped knocked down. Available in 8, 14, 18, and 24 inch heights.

Cliplock curbs use interlocking tabs to fasten together. No tools required.

Hinged curb corners fasten together with furnished hinge pins.

Standard roof curb corners fasten together with furnished hardware.

NOTE - 090 models can be used on smaller 79-3/4 in. roof curbs (not full perimeter) with 15-3/4 in. overhang at condenser end of unit. See dimension drawing on page 38.

## OPTIONS / ACCESSORIES

Item	Catalog No.	024	030	036	048	060	072	090
<b>COOLING SYSTEM</b>								
Condensate Drain Trap	PVC - LTACDKP03/07	37K69	x	x	x	x	x	x
	Copper - LTACDKC03/07	45K67	x	x	x	x	x	x
Compressor Crankcase Heater	208/230V-1 or 3 ph - K1CCHT02A-1P	39W04	x	x	x			
	208/230V-1 or 3 ph - T1CCHT01AN1P	95M07			x	x		
	460V-3ph - K1CCHT012A-1G	39W05			x			
	460V-3ph - T1CCHT01AN1G	95M08			x	x		
	575V-3ph - K1CCHT02A-1J	39W06			x			
	575V-3ph - T1CCHT01AN1J	95M09			x	x		
Low Ambient Kit	K1SNSR33AN1	41W33	x	x	x	x	x	x
Efficiency	Standard		○	○	○	○	○	○
Refrigerant Type	R-410A		○	○	○	○	○	○
<b>HEATING SYSTEM</b>								
Bottom Gas Piping Kit	T1GPKT01AN1	19W50	x	x	x	x	x	x
Low Temperature Vestibule Heater	208/230V-1 or 3 ph - T1CWKT01AN1Y	19W53	x	x	x	x	x	x
	460V-3ph - T1CWKT01AN1G	19W54			x	x	x	x
	575V-3ph - T1CWKT01AN1J	19W62			x	x	x	x
Combustion Air Intake Extensions	T1EXTN10AN1	19W51	x	x	x	x	x	x
Gas Heat Input	Standard One-Stage - 65 kBtuh input		○	○	○	○	○	○
	Medium One-Stage - 105 kBtuh input				○	○	○	○
	High Two-Stage - 105/150 kBtuh input				○	○	○	○
	High One-Stage - 150 kBtuh input				○	○	○	○
LPG/Propane Conversion Kits	For one-stage models - C1PROP10AP1	53W69	x	x	x	x	x	x
	For two-stage models - C1PROP20AP1	53W70			x	x	x	x
Stainless Steel Heat Exchanger			○	○	○	○	○	○
Vertical Vent Extension	C1EXTN20FF1	31W62	x	x	x	x	x	x
<b>BLOWER - SUPPLY AIR</b>								
Motors	Direct Drive - 0.25 hp		○	○				
	Direct Drive - 0.5 hp				○	○		
	Direct Drive - 0.75 hp					○		
	Belt Drive - 1 hp Standard Efficiency							○
	Belt Drive - 1.5 hp Standard Efficiency				○	○	○	
	<sup>1</sup> Belt Drive - 2 hp Standard Efficiency				○	○	○	○
	Belt Drive - 3 hp Standard Efficiency							○
Drive Kits	Kit A01 - T1DRKT001-1 - 673-1010 rpm				○			
See Blower Data Tables for selection	Kit A02 - T1DRKT002-1 - 745-1117 rpm				○			
	Kit A03 - T1DRKT003-1 - 833-1250 rpm					○		
	Kit A04 - T1DRKT004-1 - 968-1340 rpm						○	
	Kit A05 - T1DRKT005-1 - 897-1346 rpm				○			
	Kit A06 - T1DRKT006-1 - 1071-1429 rpm				○			
	Kit A07 - T1DRKT007-1 - 1212-1548 rpm					○		
	Kit A08 - T1DRKT008-1 - 1193-1591 rpm						○	
	Kit AA01 - T1DRKT001AP1 - 522-784 rpm							○
	Kit AA02 - T1DRKT002AP1 - 632-875 rpm							○
	Kit AA03 - T1DRKT003AP1 - 798-1105 rpm							○
	Kit AA04 - T1DRKT004AP1 - 921-1228 rpm							○

**NOTE** - The catalog and model numbers that appear here are for ordering field installed accessories only.

⊗ - Field Installed or Configure to Order (factory installed)

○ - Configure to Order (Factory Installed)

x - Field Installed.

<sup>1</sup> 2 hp blower motor is not available for 208/230V-1ph applications.

## OPTIONS / ACCESSORIES

Item	Catalog No.	024	030	036	048	060	072	090
<b>CABINET</b>								
Coil Guards	T1GARD20A-1	17W87	x	x	x	x	x	
	T1GARD20N-1	17W88					x	
	K1GARD20AP1	53W21						x
Corrosion Protection		○	○	○	○	○	○	○
Hail Guards	T1GARD10A-1	17W89	x	x	x	x		
	T1GARD10N-1	17W90					x	
	K1GARD10AP1	53W22						x
Hinged Access Panels		○	○	○	○	○	○	○
<b>CONTROLS</b>								
Dirty Filter Switch	COSWCH00AE-1	30K48	x	x	x	x	x	x
Smoke Detector - Supply or Return	T1SNSR41AN1	39W16	x	x	x	x	x	x
<b>ELECTRICAL</b>								
Voltage 60 hz	208/230V - 1 phase		○	○	○	○		
	208/230V - 3 phase				○	○	○	○
	460V - 3 phase				○	○	○	○
	575V - 3 phase				○	○	○	○
Disconnect	See Electric Data Tables for usage		⊗	⊗	⊗	⊗	⊗	⊗
GFI Service Outlets	LTAGFIK10/15	74M70	⊗	⊗	⊗	⊗	⊗	⊗
<b>ECONOMIZER</b>								
<b>Economizer</b>								
Economizer, Single Enthalpy Control Includes Outdoor Air Hood and Barometric Relief Dampers with Hood	T1ECON30A-1	36W96	⊗	⊗	⊗	⊗		
	T1ECON30N-1	36W97					⊗	⊗
Horizontal Economizer Conversion Kit	T1HECK00AN1	17W45	x	x	x	x	x	x
<b>Economizer Controls</b>								
Differential Enthalpy Sensor	T1SNSR60AN1	17W71	x	x	x	x	x	x
Single Temperature Control	TASEK10/15	76M37	x	x	x	x	x	x
Differential Temperature Control	Order 2 - TASEK10/15	76M37	x	x	x	x	x	x
<b>OUTDOOR AIR</b>								
<b>Outdoor Air Dampers</b>								
Damper Section - Manual, Includes Outdoor Air Hood	T1DAMP11A-1	16W88	x	x	x	x		
	T1DAMP11N-1	16W91					x	x
Damper Motorized Kit - Order Manual Outdoor Air Damper Separately	T1DAMP21AN1	16W92	x	x	x	x	x	x
<b>POWER EXHAUST FAN</b>								
Standard Static	208/230V-1 or 3 ph - T1PWRE10A-1P	17W39			x	x	x	
	460V-3ph - T1PWRE10A-1G	17W40			x	x	x	
	575V-3ph - T1PWRE10A-1J	17W41			x	x	x	
	208/230V-1 or 3 ph - T1PWRE10N-1P	17W42						x
	460V-3ph - T1PWRE10N-1G	17W43						x
	575V-3ph - T1PWRE10N-1J	17W44						x
								x
<b>INDOOR AIR QUALITY</b>								
<b>Indoor Air Quality (CO<sub>2</sub>) Sensors</b>								
Sensor - white case CO <sub>2</sub> display	C0SNSR50AE1L	77N39	x	x	x	x	x	x
Sensor - duct mount, black case, no display	C0SNSR53AE1L	87N54	x	x	x	x	x	x
CO <sub>2</sub> Sensor Duct Mounting Kit	C0MISC19AE1-	85L43	x	x	x	x	x	x
<b>UVC Germicidal Lamps</b>								
<sup>1</sup> Healthy Climate® UVC Light Kit (208/230v-1ph)	E1UVCL10AN1-	50W90	x	x	x	x	x	x

**NOTE** - The catalog and model numbers that appear here are for ordering field installed accessories only.

<sup>1</sup> Lamps operate on 110-230V single-phase power supply. Step-down transformer may be ordered separately for 460V and 575V units. Alternately, 110V power supply may be used to directly power the UVC ballast(s).

⊗ - Field Installed or Configure to Order (factory installed)

○ - Configure to Order (Factory Installed)

X - Field Installed.

## OPTIONS / ACCESSORIES

Item	Catalog No.	024	030	036	048	060	072	090
<b>CEILING DIFFUSERS</b>								
Step-Down - Order one	RTD9-65-R	<b>27G87</b>	x	x	x	x		
	RTD11-95	<b>29G04</b>					x	x
	(Canada Only) RTD11-95S	<b>13K61</b>					x	x
Flush - Order one	FD9-65-R	<b>27G86</b>	x	x	x	x		
	FD11-95	<b>29G08</b>					x	x
	(Canada Only) FD11-95S	<b>13K56</b>					x	x
Transitions (Supply and Return) - Order one	T1TRAN10AN1	<b>17W53</b>	x	x	x	x		
	T1TRAN20N-1	<b>17W54</b>					x	x
<b>ROOF CURBS - DOWNFLOW</b>								
<b>Cliplock</b>								
8 in. height	T1CURB23AN1	<b>16W93</b>	x	x	x	x	x	<sup>1</sup> x
	K1CURB23AP1	<b>52W20</b>						x
14 in. height	T1CURB20AN1	<b>16W94</b>	x	x	x	x	x	<sup>1</sup> x
	K1CURB20AP1	<b>52W21</b>						x
18 in. height	T1CURB21AN1	<b>16W95</b>	x	x	x	x	x	<sup>1</sup> x
	K1CURB21AP1	<b>52W22</b>						x
24 in. height	T1CURB22AN1	<b>16W96</b>	x	x	x	x	x	<sup>1</sup> x
	K1CURB22AP1	<b>52W23</b>						x
<b>Hinged</b>								
8 in. height	T1CURB30AN1	<b>17W46</b>	x	x	x	x	x	<sup>1</sup> x
	K1CURB30AP1	<b>52W17</b>						x
18 in. height	T1CURB32AN1	<b>17W47</b>	x	x	x	x	x	<sup>1</sup> x
	K1CURB32AP1	<b>52W18</b>						x
24 in. height	T1CURB33AN1	<b>17W48</b>	x	x	x	x	x	<sup>1</sup> x
	K1CURB33AP1	<b>52W19</b>						x
<b>Standard</b>								
14 in. height	T1CURB10AN1	<b>13W27</b>	x	x	x	x	x	<sup>1</sup> x
	K1CURB10AP1	<b>52W24</b>						x

**NOTE** - The catalog and model numbers that appear here are for ordering field installed accessories only.

⊗ - Field Installed or Configure to Order (factory installed)

○ - Configure to Order (Factory Installed)

**X** - Field Installed.

<sup>1</sup> 090 models will fit smaller roof curbs with overhang. See dimension drawing.

**SPECIFICATIONS - DIRECT DRIVE BLOWER**
**2 - 2.5 TON**

General Data		Nominal Tonnage	2 Ton	2.5 Ton
		Model No.	KGA024S4D	KGA030S4D
		Efficiency Type	Standard	Standard
<b>Cooling Performance</b>	Gross Cooling Capacity - Btuh		24,400	29,800
	<sup>1</sup> Net Cooling Capacity - Btuh		23,600	28,800
	AHRI Rated Air Flow - cfm		840	1000
	<sup>2</sup> Sound Rating Number (dB)		75	75
	Total Unit Power - kW		2.1	2.6
	<sup>1</sup> SEER (Btuh/Watt)		13	13
	<sup>1</sup> EER (Btuh/Watt)		11.4	11.2
<b>Refrigerant</b>	Type		R-410A	R-410A
	Charge Furnished		7 lbs. 0 oz.	7 lbs. 12 oz.
<b>Gas Heating Options - See Page 12</b>			<b>Standard (1 Stage)</b>	<b>Standard (1 Stage)</b>
<b>Compressor Type (one per unit)</b>			Scroll	Scroll
<b>Outdoor Coil</b>	Net face area - sq. ft.		15.6	15.6
	Tube diameter - in.		3/8	3/8
	Number of rows		1	1
	Fins per inch		20	20
<b>Outdoor Coil Fan</b>	Motor HP		1/4	1/4
	Motor rpm		825	825
	Total motor watts		250	250
	Diameter - in. / No. of blades		24 - 3	24 - 3
	Total air volume - cfm		3700	3700
<b>Indoor Coil</b>	Net face area - sq. ft.		7.8	7.8
	Tube diameter - in.		3/8	3/8
	Number of rows		3	3
	Fins per inch		14	14
	Drain Connection (no. and size) - in.		(1) 3/4 npt	(1) 3/4 npt
	Expansion device type		Balanced Port Thermostatic Expansion Valve, removeable power head	
<b>Indoor Blower</b>	Nominal Motor HP		.25	.25
	Wheel nominal diameter x width - in.		10 x 10	10 x 10
<b>Filters</b>	Type		Disposable	
	Number and size - in.		(4) 16 x 20 x 2	
<b>Electrical Characteristics - 60 Hz</b>			208/230V 1 phase	208/230V 1 phase

NOTE - Net capacity includes evaporator blower motor heat deduction. Gross capacity does not include evaporator blower motor heat deduction.

<sup>1</sup> Certified in accordance with the USE certification program, which is based on AHRI Standard 210/240; 95°F outdoor air temperature and 80°F db/67°F wb entering evaporator air; minimum external duct static pressure.

<sup>2</sup> Sound Rating Number rated in accordance with test conditions included in AHRI Standard 270.

**SPECIFICATIONS - DIRECT DRIVE BLOWER**
**3 - 5 TON**

General Data		Nominal Tonnage	3 Ton	4 Ton	5 Ton
		Model No.	KGA036S4D	KGA048S4D	KGA060S4D
		Efficiency Type	Standard	Standard	Standard
<b>Cooling Performance</b>	Gross Cooling Capacity - Btuh		37,500	50,000	61,800
	<sup>1</sup> Net Cooling Capacity - Btuh		36,000	48,000	59,000
	AHRI Rated Air Flow - cfm		1200	1600	1800
	<sup>2</sup> Sound Rating Number (dB)		75	75	82
	Total Unit Power - kW		3.4	4.4	5.3
	<sup>1</sup> SEER (Btuh/Watt)		13	13	13
	<sup>1</sup> EER (Btuh/Watt)		10.7	11	11.2
<b>Refrigerant</b>	Type		R-410A	R-410A	R-410A
	Charge Furnished		8 lbs. 5 oz.	8 lbs. 10 oz.	11 lbs. 0 oz.
<b>Gas Heating Options - See Page 12</b>			<b>Standard or Medium (1 Stage)</b>	<b>Standard, Medium (1 Stage) or High (1 or 2 Stage)</b>	
<b>Compressor Type (one per unit)</b>			Scroll	Scroll	Scroll
<b>Outdoor Coil</b>	Net face area - sq. ft.		15.6	15.6	15.6
	Tube diameter - in.		3/8	3/8	3/8
	Number of rows		1	1.5	2
	Fins per inch		20	20	20
<b>Outdoor Coil Fan</b>	Motor HP		1/4	1/4	1/3
	Motor rpm		825	825	1075
	Total motor watts		250	250	370
	Diameter - in. / No. of blades		24 - 3	24 - 3	24 - 3
	Total air volume - cfm		3700	3500	4300
<b>Indoor Coil</b>	Net face area - sq. ft.		7.8	7.8	7.8
	Tube diameter - in.		3/8	3/8	3/8
	Number of rows		3	3	4
	Fins per inch		14	14	14
	Drain Connection (no. and size) - in.		(1) 3/4 npt	(1) 3/4 npt	(1) 3/4 npt
	Expansion device type		Balanced Port Thermostatic Expansion Valve, removeable power head		
<b>Indoor Blower</b>	Nominal Motor HP		.5	.5	.75
	Wheel nominal diameter x width - in.		10 x 10	10 x 10	11 x 10
<b>Filters</b>	Type		Disposable		
	Number and size - in.		(4) 16 x 20 x 2		
<b>Electrical Characteristics - 60 Hz</b>			208/230V 1 phase	208/230V 1 phase	208/230V 1 phase
			208/230V, 460V & 575V 3 phase	208/230V, 460V & 575V 3 phase	208/230V, 460V & 575V 3 phase

NOTE - Net capacity includes evaporator blower motor heat deduction. Gross capacity does not include evaporator blower motor heat deduction.

<sup>1</sup> Certified in accordance with the USE certification program, which is based on AHRI Standard 210/240; 95°F outdoor air temperature and 80°F db/67°F wb entering evaporator air; minimum external duct static pressure.

<sup>2</sup> Sound Rating Number rated in accordance with test conditions included in AHRI Standard 270.

**SPECIFICATIONS - BELT DRIVE BLOWER**
**3 - 7.5 TON**

General Data		Nominal Tonnage	3 Ton	4 Ton	5 Ton	6 Ton	7.5 Ton
		Model No.	KGA036S4B	KGA048S4B	KGA060S4B	KGA072S4B	KGA090S4B
		Efficiency Type	Standard	Standard	Standard	Standard	Standard
<b>Cooling Performance</b>	Gross Cooling Capacity - Btuh		37,500	50,000	61,800	72,800	92,000
	Net Cooling Capacity - Btuh		<sup>1</sup> 36,000	<sup>1</sup> 48,000	<sup>1</sup> 59,000	<sup>2</sup> 70,000	<sup>2</sup> 90,000
	AHRI Rated Air Flow - cfm		1200	1600	1800	2100	2660
	<sup>4</sup> Sound Rating Number (dB)		75	75	82	82	79
	Total Unit Power - kW		3.4	4.4	5.3	6.3	8.2
	<sup>1</sup> SEER (Btuh/Watt)		13.0	13.0	13.0	---	---
	<sup>3</sup> IEER (Btuh/Watt)		---	---	---	11.2	11.2
	EER (Btuh/Watt)		<sup>1</sup> 10.7	<sup>1</sup> 11	<sup>1</sup> 11.2	<sup>2</sup> 11.0	<sup>2</sup> 11.0
<b>Refrigerant</b>	Type		R-410A	R-410A	R-410A	R-410A	R-410A
	Charge Furnished		8 lbs. 5 oz.	8 lbs. 10 oz.	11 lbs. 0 oz.	14 lbs. 12 oz.	17 lbs. 0 oz.
<b>Gas Heating Options - See Page 12</b>			<b>Standard or Medium (1 Stage)</b>	<b>Standard, Medium (1 Stage) or High (1 or 2 Stage)</b>			<b>Medium (1 Stage) or High (1 or 2 Stage)</b>
<b>Compressor Type (one per unit)</b>			Scroll	Scroll	Scroll	Scroll	Scroll
<b>Outdoor Coil</b>	Net face area - sq. ft.		15.6	15.6	15.6	19.3	28.0
	Tube diameter - in.		3/8	3/8	3/8	3/8	3/8
	Number of rows		1	1.5	2	2	2
	Fins / inch		20	20	20	20	20
<b>Outdoor Coil Fan</b>	Motor HP		1/4	1/4	1/3	1/3	1/3
	Motor rpm		825	825	1075	1075	1075
	Total motor watts		250	250	370	405	350
	Diameter - in. / No. of blades		24 - 3	24 - 3	24 - 3	24 - 3	24 - 4
	Total air volume - cfm		3700	3500	4300	4800	4900
<b>Indoor Coil</b>	Net face area - sq. ft.		7.8	7.8	7.8	9.7	9.7
	Tube diameter - in.		3/8	3/8	3/8	3/8	3/8
	Number of rows		3	3	4	4	4
	Fins per inch		14	14	14	14	14
	Drain Connection (no. and size) - in.		(1) 3/4 NPT	(1) 3/4 NPT	(1) 3/4 NPT	(1) 3/4 NPT	(1) 3/4 NPT
	Expansion device type		Balanced Port Thermostatic Expansion Valve, removeable power head				
<b><sup>5</sup> Indoor Blower &amp; Drive Selection</b>	Nominal Motor HP		1.5 hp, <sup>6</sup> 2 hp	1.5 hp, <sup>6</sup> 2 hp	1.5 hp, <sup>6</sup> 2 hp	1.5 hp, 2 hp	1 hp, 2 hp, 3 hp
	Maximum Usable Motor HP		1.72 hp, 2.3 hp	1.72 hp, 2.3 hp	1.72 hp, 2.3 hp	1.72 hp, 2.3 hp	1.15 hp, 2.3 hp, 3.45 hp
	Available Drive Kits		A01 673 - 1010 rpm A05 897 - 1346 rpm	A02 745 - 1117 rpm A06 1071 - 1429 rpm	A03 833 - 1250 rpm A07 1212 - 1548 rpm	A04 968 - 1340 rpm A08 1193 - 1591 rpm	AA01 522 - 784 rpm AA02 632 - 875 rpm AA03 798 - 1105 rpm AA04 921 - 1228 rpm
	Wheel nominal diameter x width - in.		10 x 10	10 x 10	10 x 10	10 x 10	15 x 9
<b>Filters</b>	Type		Disposable			Disposable	
	Number and size - in.		(4) 16 x 20 x 2			(4) 20 x 20 x 2	
<b>Electrical Characteristics - 60 Hz</b>			208/230V 1 phase	208/230V, 1 phase	208/230V 1 phase	208/230V, 460V & 575V 3 phase	208/230V, 460V & 575V 3 phase
			208/230V, 460V & 575V 3 phase	208/230V 460V & 575V 3 phase	208/230V, 460V & 575V 3 phase		

NOTE - Net capacity includes evaporator blower motor heat deduction. Gross capacity does not include evaporator blower motor heat deduction.

<sup>1</sup> Certified in accordance with the USE certification program, which is based on AHRI Standard 210/240; 95°F outdoor air temperature and 80°F db/67°F wb entering evaporator air; minimum external duct static pressure.

<sup>2</sup> Certified in accordance with the ULE certification program, which is based on AHRI Standard 340/360; 95°F outdoor air temperature and 80°F db/67°F wb entering evaporator air; minimum external duct static pressure.

<sup>3</sup> Integrated Energy Efficiency Ratio certified and tested according to AHRI Standard 340/360.

<sup>4</sup> Sound Rating Number rated in accordance with test conditions included in AHRI Standard 270.

<sup>5</sup> Using total air volume and system static pressure requirements determine from blower performance tables rpm and motor hp required. Maximum usable hp of motors furnished are shown. In Canada, nominal motor hp is also maximum usable motor hp output. If motors of comparable hp are used, be sure to keep within the service factor limitations outlined on the motor nameplate.

<sup>6</sup> 2 hp blower motor is not available for 208/230V-1ph applications.

## SPECIFICATIONS - GAS HEAT

Model No.	KGA024, KGA030	KGA036, KGA048, KGA060, KGA072	KGA036, KGA048, KGA060, KGA072, KGA090	KGA048, KGA060, KGA072, KGA090	
Heat Input Type	<b>Standard (1 Stage)</b>	<b>Standard (1 Stage)</b>	<b>Medium (1 Stage)</b>	<b>High (1 Stage)</b>	<b>High (2 Stage)</b>
Input - Btuh First Stage	65,000	65,000	105,000	150,000	105,000
Second Stage	---	---	---	---	150,000
Output - Btuh First Stage	52,000	52,000	84000	120,000	85,500
Second Stage	---	---	---	---	120,000
Temperature Rise Range	35 - 65°F	20 - 50°F	30 - 75°F	40 - 85°F	40 - 85°F
<sup>1</sup> AFUE	80%	80%	80%	80%	80%
Thermal Efficiency	80%	80%	80%	80%	81.5%/80%
Gas Supply Connections	1/2 in. NPT				
Rec. Gas Supply Pressure - Natural / LPG	7 in. w.g. / 11 in. w.g.				

<sup>1</sup> Annual Fuel Utilization Efficiency based on U.S. DOE test procedures and FTC labeling regulations.

## HIGH ALTITUDE DERATE

NOTE - Units may be installed at altitudes up to 2000 ft. above sea level without any modifications.  
At altitudes above 2000 ft. units must be derated to match information in the table shown.  
At altitudes above 4500 ft. unit must be derated 2% for each 1000 ft. above sea level.

NOTE - This is the only permissible derate for these units.

Heat Input Type	Altitude Feet	Gas Manifold Pressure in. w.g.		Input Rate (Btuh)
		Natural Gas	LPG/Propane	
Standard (1 stage)	2001 - 4500	3.0	8.7	60,000
Medium (1 stage)	2001 - 4500	3.0	8.7	97,000
High (1 stage)	2001 - 4500	3.0	8.7	138,000
High (2 stage)	2001 - 4500	3.0/1.7	8.7/5.5	138,000/ 105,000

# COOLING RATINGS

NOTE - For Temperatures and Capacities not shown in tables, see bulletin - Cooling Unit Rating Table Correction Factor Data in Miscellaneous Engineering Data section.

## 2 TON STANDARD EFFICIENCY - COOLING CAPACITY

KGA024S4

Entering Wet Bulb Temperature	Total Air Volume		Outdoor Air Temperature Entering Outdoor Coil																							
			85°F (29°C)						95°F (35°C)						105°F (41°C)						115°F (46°C)					
			Total Cooling Capacity		Comp Motor kW Input	Sensible To Total Ratio (S/T) Dry Bulb			Total Cooling Capacity		Comp Motor kW Input	Sensible To Total Ratio (S/T) Dry Bulb			Total Cooling Capacity		Comp Motor kW Input	Sensible To Total Ratio (S/T) Dry Bulb			Total Cooling Capacity		Comp Motor kW Input	Sensible To Total Ratio (S/T) Dry Bulb		
			kBtuh	kW		75°F 24°C	80°F 27°C	85°F 29°C	kBtuh	kW		75°F 24°C	80°F 27°C	85°F 29°C	kBtuh	kW		75°F 24°C	80°F 27°C	85°F 29°C	kBtuh	kW		75°F 24°C	80°F 27°C	85°F 29°C
63°F (17°C)	640	300	23.2	6.8	1.39	.72	.86	.99	22.0	6.4	1.59	.74	.88	1.00	20.8	6.1	1.82	.75	.91	1.00	19.5	5.7	2.07	.78	.94	1.00
	800	380	24.2	7.1	1.39	.78	.94	1.00	23.0	6.7	1.59	.80	.97	1.00	21.8	6.4	1.82	.82	.99	1.00	20.5	6.0	2.08	.85	1.00	1.00
	960	455	25.1	7.4	1.39	.84	1.00	1.00	24.0	7.0	1.60	.86	1.00	1.00	22.8	6.7	1.83	.89	1.00	1.00	21.5	6.3	2.08	.93	1.00	1.00
67°F (19°C)	640	300	24.8	7.3	1.39	.56	.70	.82	23.6	6.9	1.60	.57	.71	.85	22.3	6.5	1.82	.58	.73	.87	20.8	6.1	2.08	.60	.75	.90
	800	380	25.8	7.6	1.39	.60	.75	.90	24.4	7.2	1.60	.61	.77	.93	23.0	6.7	1.83	.63	.80	.96	21.5	6.3	2.09	.64	.83	1.00
	960	455	26.4	7.7	1.40	.63	.81	.98	25.0	7.3	1.60	.65	.84	1.00	23.5	6.9	1.83	.66	.87	1.00	22.0	6.4	2.09	.69	.90	1.00
71°F (22°C)	640	300	26.6	7.8	1.40	.42	.55	.67	25.3	7.4	1.60	.43	.56	.68	23.9	7.0	1.84	.43	.56	.70	22.3	6.5	2.09	.43	.58	.73
	800	380	27.5	8.1	1.40	.44	.59	.73	26.1	7.6	1.61	.44	.60	.75	24.6	7.2	1.84	.45	.61	.78	23.0	6.7	2.10	.45	.63	.80
	960	455	28.2	8.3	1.40	.45	.62	.79	26.7	7.8	1.61	.46	.64	.82	25.1	7.4	1.85	.46	.66	.85	23.4	6.9	2.11	.47	.68	.88

## 2.5 TON STANDARD EFFICIENCY - COOLING CAPACITY

KGA030S4

Entering Wet Bulb Temperature	Total Air Volume		Outdoor Air Temperature Entering Outdoor Coil																							
			85°F (29°C)						95°F (35°C)						105°F (41°C)						115°F (46°C)					
			Total Cooling Capacity		Comp Motor kW Input	Sensible To Total Ratio (S/T) Dry Bulb			Total Cooling Capacity		Comp Motor kW Input	Sensible To Total Ratio (S/T) Dry Bulb			Total Cooling Capacity		Comp Motor kW Input	Sensible To Total Ratio (S/T) Dry Bulb			Total Cooling Capacity		Comp Motor kW Input	Sensible To Total Ratio (S/T) Dry Bulb		
			kBtuh	kW		75°F 24°C	80°F 27°C	85°F 29°C	kBtuh	kW		75°F 24°C	80°F 27°C	85°F 29°C	kBtuh	kW		75°F 24°C	80°F 27°C	85°F 29°C	kBtuh	kW		75°F 24°C	80°F 27°C	85°F 29°C
63°F (17°C)	800	380	28.3	8.3	1.77	.72	.86	1.00	26.9	7.9	2.02	.73	.88	1.00	25.5	7.5	2.29	.75	.90	1.00	23.9	7.0	2.62	.77	.94	1.00
	1000	470	29.5	8.6	1.78	.78	.94	1.00	28.1	8.2	2.02	.79	.97	1.00	26.6	7.8	2.30	.82	.99	1.00	25.1	7.4	2.63	.85	1.00	1.00
	1200	565	30.5	8.9	1.79	.84	1.00	1.00	29.3	8.6	2.03	.86	1.00	1.00	27.9	8.2	2.31	.89	1.00	1.00	26.3	7.7	2.62	.92	1.00	1.00
67°F (19°C)	800	380	30.2	8.9	1.78	.56	.69	.82	28.8	8.4	2.03	.57	.71	.84	27.2	8.0	2.30	.58	.73	.87	25.5	7.5	2.63	.59	.75	.91
	1000	470	31.3	9.2	1.79	.59	.75	.91	29.8	8.7	2.03	.60	.77	.93	28.1	8.2	2.31	.62	.80	.96	26.3	7.7	2.63	.63	.82	1.00
	1200	565	32.1	9.4	1.80	.63	.81	.98	30.5	8.9	2.04	.64	.83	1.00	28.8	8.4	2.32	.66	.86	1.00	26.9	7.9	2.64	.68	.90	1.00
71°F (22°C)	800	380	32.4	9.5	1.80	.42	.54	.66	30.8	9.0	2.04	.42	.55	.68	29.2	8.6	2.32	.43	.56	.70	27.3	8.0	2.64	.43	.58	.72
	1000	470	33.4	9.8	1.81	.43	.58	.72	31.8	9.3	2.05	.44	.59	.74	30.0	8.8	2.33	.44	.61	.77	28.1	8.2	2.64	.45	.63	.80
	1200	565	34.2	10.0	1.82	.44	.62	.79	32.4	9.5	2.06	.45	.63	.81	30.6	9.0	2.33	.46	.65	.84	28.6	8.4	2.65	.47	.67	.88

## 3 TON STANDARD EFFICIENCY - COOLING CAPACITY

KGA036S4

Entering Wet Bulb Temperature	Total Air Volume		Outdoor Air Temperature Entering Outdoor Coil																							
			85°F (29°C)						95°F (35°C)						105°F (41°C)						115°F (46°C)					
			Total Cooling Capacity		Comp Motor kW Input	Sensible To Total Ratio (S/T) Dry Bulb			Total Cooling Capacity		Comp Motor kW Input	Sensible To Total Ratio (S/T) Dry Bulb			Total Cooling Capacity		Comp Motor kW Input	Sensible To Total Ratio (S/T) Dry Bulb			Total Cooling Capacity		Comp Motor kW Input	Sensible To Total Ratio (S/T) Dry Bulb		
			kBtuh	kW		75°F 24°C	80°F 27°C	85°F 29°C	kBtuh	kW		75°F 24°C	80°F 27°C	85°F 29°C	kBtuh	kW		75°F 24°C	80°F 27°C	85°F 29°C	kBtuh	kW		75°F 24°C	80°F 27°C	85°F 29°C
63°F (17°C)	960	455	35.6	10.4	2.33	.72	.85	.98	34.0	10.0	2.65	.73	.87	.99	32.2	9.4	3.01	.75	.89	1.00	30.3	8.9	3.44	.77	.92	1.00
	1200	565	37.0	10.8	2.34	.77	.93	1.00	35.4	10.4	2.66	.79	.95	1.00	33.5	9.8	3.02	.81	.98	1.00	31.6	9.3	3.45	.84	1.00	1.00
	1440	680	38.3	11.2	2.36	.83	.99	1.00	36.6	10.7	2.67	.85	1.00	1.00	35.0	10.3	3.04	.87	1.00	1.00	33.2	9.7	3.46	.90	1.00	1.00
67°F (19°C)	960	455	38.0	11.1	2.35	.56	.69	.82	36.3	10.6	2.67	.57	.71	.84	34.4	10.1	3.03	.58	.72	.86	32.3	9.5	3.46	.59	.74	.89
	1200	565	39.3	11.5	2.37	.60	.75	.89	37.5	11.0	2.69	.61	.77	.92	35.5	10.4	3.05	.62	.79	.94	33.4	9.8	3.48	.63	.81	.97
	1440	680	40.3	11.8	2.38	.63	.80	.96	38.4	11.3	2.70	.64	.83	.98	36.3	10.6	3.06	.66	.85	1.00	34.1	10.0	3.49	.68	.88	1.00
71°F (22°C)	960	455	40.6	11.9	2.38	.42	.54	.67	38.7	11.3	2.70	.43	.55	.68	36.8	10.8	3.07	.43	.56	.70	34.6	10.1	3.49	.43	.58	.72
	1200	565	41.9	12.3	2.40	.43	.58	.72	39.9	11.7	2.72	.44	.59	.74	37.8	11.1	3.08	.44	.61	.76	35.6	10.4	3.51	.45	.62	.79
	1440	680	42.8	12.5	2.41	.45	.62	.78	40.7	11.9	2.73	.45	.63	.80	38.6	11.3	3.10	.46	.65	.83	36.2	10.6	3.52	.47	.67	.86

## 4 TON STANDARD EFFICIENCY - COOLING CAPACITY

KGA048S4

Entering Wet Bulb Temperature	Total Air Volume		Outdoor Air Temperature Entering Outdoor Coil																							
			85°F (29°C)						95°F (35°C)						105°F (41°C)						115°F (46°C)					
			Total Cooling Capacity		Comp Motor kW Input	Sensible To Total Ratio (S/T) Dry Bulb			Total Cooling Capacity		Comp Motor kW Input	Sensible To Total Ratio (S/T) Dry Bulb			Total Cooling Capacity		Comp Motor kW Input	Sensible To Total Ratio (S/T) Dry Bulb			Total Cooling Capacity		Comp Motor kW Input	Sensible To Total Ratio (S/T) Dry Bulb		
			kBtuh	kW		75°F 24°C	80°F 27°C	85°F 29°C	kBtuh	kW		75°F 24°C	80°F 27°C	85°F 29°C	kBtuh	kW		75°F 24°C	80°F 27°C	85°F 29°C	kBtuh	kW		75°F 24°C	80°F 27°C	85°F 29°C
63°F (17°C)	1280	605	47.9	14.0	3.05	.71	.85	.98	45.6	13.4	3.47	.72	.87	1.00	43.2	12.7	3.94	.74	.90	1.00	40.6	11.9	4.48	.76	.93	1.00
	1600	755	49.7	14.6	3.07	.76	.93	1.00	47.3	13.9	3.49	.78	.95	1.00	44.9	13.2	3.96	.80	.98	1.00	42.4	12.4	4.50	.83	1.00	1.00
	1920	905	51.3	15.0	3.08	.82	.99	1.00	49.1	14.4	3.51	.84	1.00	1.00	46.7	13.7	3.98	.87	1.00	1.00	44.2	13.0	4.53	.90	1.00	1.00
67°F (19°C)	1280	605	50.9	14.9	3.07	.55	.68	.81	48.4	14.2	3.51	.56	.70	.83	45.8	13.4	3.98	.57	.71	.86	43.1	12.6	4.51	.58	.73	.89
	1600	755	52.6	15.4	3.09	.58	.74	.89	50.0	14.7	3.52	.60	.76	.92	47.2	13.8	4.00	.61	.78	.95	44.3	13.0	4.53	.63	.81	.98
	1920	905	53.8	15.8	3.09	.62	.80	.97	51.0	14.9	3.53	.63	.82	.99	48.2	14.1	4.01	.65	.85	1.00	45.3	13.3	4.55	.67	.88	1.00
71°F (22°C)	1280	605	54.3	15.9	3.09	.41	.54	.66	51.6	15.1	3.54	.42	.55	.67	48.8	14.3	4.02	.42	.56	.69	45.9	13.5	4.56	.43	.57	.71
	1600	755	56.0	16.4	3.11	.43	.57	.71	53.1	15.6	3.55	.43	.58	.73	50.2	14.7	4.04	.44	.60	.76	47.1	13.8	4.58	.44	.61	.79
	1920	905	57.0	16.7	3.11	.44	.61	.77	54.1	15.9	3.57	.44	.62	.80	51.0	14.9	4.05	.45	.64	.83	47.8	14.0	4.59	.46	.66	.86

# COOLING RATINGS

NOTE - For Temperatures and Capacities not shown in tables, see bulletin - Cooling Unit Rating Table Correction Factor Data in Miscellaneous Engineering Data section.

## 5 TON STANDARD EFFICIENCY - COOLING CAPACITY

KGA060S4

Entering Wet Bulb Temperature	Total Air Volume		Outdoor Air Temperature Entering Outdoor Coil																							
			85°F (29°C)						95°F (35°C)						105°F (41°C)						115°F (46°C)					
			Total Cooling Capacity		Comp Motor kW Input	Sensible To Total Ratio (S/T) Dry Bulb			Total Cooling Capacity		Comp Motor kW Input	Sensible To Total Ratio (S/T) Dry Bulb			Total Cooling Capacity		Comp Motor kW Input	Sensible To Total Ratio (S/T) Dry Bulb			Total Cooling Capacity		Comp Motor kW Input	Sensible To Total Ratio (S/T) Dry Bulb		
			kBtuh	kW		75°F 24°C	80°F 27°C	85°F 29°C	kBtuh	kW		75°F 24°C	80°F 27°C	85°F 29°C	kBtuh	kW		75°F 24°C	80°F 27°C	85°F 29°C	kBtuh	kW		75°F 24°C	80°F 27°C	85°F 29°C
63°F (17°C)	1600	755	59.2	17.3	3.53	.67	.83	.99	56.4	16.5	4.01	.68	.86	1.00	53.4	15.6	4.56	.70	.89	1.00	50.1	14.7	5.20	.72	.93	1.00
	2000	945	61.5	18.0	3.56	.73	.93	1.00	58.7	17.2	4.04	.75	.96	1.00	55.6	16.3	4.59	.78	.99	1.00	52.6	15.4	5.22	.82	1.00	1.00
	2400	1135	63.8	18.7	3.58	.80	1.00	1.00	61.1	17.9	4.06	.83	1.00	1.00	58.1	17.0	4.62	.86	1.00	1.00	54.8	16.1	5.25	.91	1.00	1.00
67°F (19°C)	1600	755	63.0	18.5	3.58	.52	.65	.78	59.9	17.6	4.05	.53	.66	.81	56.6	16.6	4.60	.54	.68	.85	53.1	15.6	5.24	.55	.70	.89
	2000	945	65.0	19.0	3.60	.55	.70	.89	61.8	18.1	4.08	.57	.72	.93	58.3	17.1	4.63	.58	.75	.96	54.5	16.0	5.26	.60	.79	1.00
	2400	1135	66.4	19.5	3.62	.59	.77	.98	63.1	18.5	4.10	.60	.80	1.00	59.5	17.4	4.65	.62	.84	1.00	55.7	16.3	5.28	.64	.88	1.00
71°F (22°C)	1600	755	67.1	19.7	3.63	.39	.51	.62	63.8	18.7	4.11	.39	.52	.64	60.3	17.7	4.66	.40	.53	.66	56.5	16.6	5.29	.40	.54	.68
	2000	945	69.0	20.2	3.65	.40	.54	.68	65.5	19.2	4.13	.41	.56	.70	61.8	18.1	4.68	.41	.57	.72	57.8	16.9	5.31	.42	.59	.76
	2400	1135	70.3	20.6	3.67	.42	.58	.75	66.7	19.5	4.15	.42	.59	.78	62.9	18.4	4.70	.43	.61	.81	58.8	17.2	5.33	.44	.63	.86

## 6 TON STANDARD EFFICIENCY - COOLING CAPACITY

KGA072S4

Entering Wet Bulb Temperature	Total Air Volume		Outdoor Air Temperature Entering Outdoor Coil																							
			85°F (29°C)						95°F (35°C)						105°F (41°C)						115°F (46°C)					
			Total Cooling Capacity		Comp Motor kW Input	Sensible To Total Ratio (S/T) Dry Bulb			Total Cooling Capacity		Comp Motor kW Input	Sensible To Total Ratio (S/T) Dry Bulb			Total Cooling Capacity		Comp Motor kW Input	Sensible To Total Ratio (S/T) Dry Bulb			Total Cooling Capacity		Comp Motor kW Input	Sensible To Total Ratio (S/T) Dry Bulb		
			kBtuh	kW		75°F 24°C	80°F 27°C	85°F 29°C	kBtuh	kW		75°F 24°C	80°F 27°C	85°F 29°C	kBtuh	kW		75°F 24°C	80°F 27°C	85°F 29°C	kBtuh	kW		75°F 24°C	80°F 27°C	85°F 29°C
63°F (17°C)	1920	905	68.9	20.2	4.60	.65	.81	.99	65.8	19.3	5.12	.67	.84	1.00	62.4	18.3	5.71	.68	.87	1.00	58.7	17.2	6.39	.70	.91	1.00
	2400	1135	71.8	21.0	4.61	.71	.92	1.00	68.7	20.1	5.13	.73	.95	1.00	65.3	19.1	5.73	.76	.98	1.00	61.8	18.1	6.40	.79	1.00	1.00
	2880	1360	74.6	21.9	4.62	.78	1.00	1.00	71.7	21.0	5.14	.81	1.00	1.00	68.5	20.1	5.73	.84	1.00	1.00	65.0	19.0	6.41	.88	1.00	1.00
67°F (19°C)	1920	905	73.6	21.6	4.62	.51	.63	.77	70.4	20.6	5.14	.52	.64	.79	66.8	19.6	5.73	.53	.66	.82	62.8	18.4	6.41	.54	.68	.86
	2400	1135	76.3	22.4	4.62	.54	.68	.87	72.8	21.3	5.15	.55	.70	.90	69.1	20.3	5.75	.56	.73	.94	64.9	19.0	6.43	.58	.76	.98
	2880	1360	78.3	22.9	4.63	.57	.75	.97	74.7	21.9	5.16	.58	.78	.99	70.8	20.7	5.76	.60	.81	1.00	66.6	19.5	6.44	.62	.85	1.00
71°F (22°C)	1920	905	79.0	23.2	4.63	.38	.49	.61	75.5	22.1	5.16	.39	.50	.62	71.7	21.0	5.76	.39	.51	.63	67.6	19.8	6.44	.39	.52	.65
	2400	1135	81.6	23.9	4.64	.39	.53	.66	77.9	22.8	5.17	.40	.54	.68	74.0	21.7	5.77	.40	.55	.70	69.6	20.4	6.45	.41	.56	.73
	2880	1360	83.4	24.4	4.65	.41	.56	.72	79.6	23.3	5.18	.41	.57	.75	75.5	22.1	5.78	.42	.59	.78	71.0	20.8	6.47	.42	.61	.82

## 7.5 TON STANDARD EFFICIENCY - COOLING CAPACITY

KGA090S4

Entering Wet Bulb Temperature	Total Air Volume		Outdoor Air Temperature Entering Outdoor Coil																							
			85°F (29°C)						95°F (35°C)						105°F (41°C)						115°F (46°C)					
			Total Cooling Capacity		Comp Motor kW Input	Sensible To Total Ratio (S/T) Dry Bulb			Total Cooling Capacity		Comp Motor kW Input	Sensible To Total Ratio (S/T) Dry Bulb			Total Cooling Capacity		Comp Motor kW Input	Sensible To Total Ratio (S/T) Dry Bulb			Total Cooling Capacity		Comp Motor kW Input	Sensible To Total Ratio (S/T) Dry Bulb		
			kBtuh	kW		75°F 24°C	80°F 27°C	85°F 29°C	kBtuh	kW		75°F 24°C	80°F 27°C	85°F 29°C	kBtuh	kW		75°F 24°C	80°F 27°C	85°F 29°C	kBtuh	kW		75°F 24°C	80°F 27°C	85°F 29°C
63°F (17°C)	2400	1135	90.1	26.4	6.17	.69	.83	.98	86.0	25.2	6.82	.70	.85	1.00	81.8	24.0	7.58	.71	.88	1.00	77.0	22.6	8.42	.73	.91	1.00
	3000	1415	94.3	27.6	6.26	.73	.92	1.00	90.0	26.4	6.92	.76	.94	1.00	85.3	25.0	7.66	.78	.98	1.00	80.4	23.6	8.51	.81	1.00	1.00
	3600	1700	97.5	28.6	6.33	.80	.99	1.00	93.2	27.3	6.99	.82	1.00	1.00	88.9	26.1	7.75	.85	1.00	1.00	84.4	24.7	8.61	.88	1.00	1.00
67°F (19°C)	2400	1135	95.5	28.0	6.29	.54	.66	.79	91.1	26.7	6.94	.55	.68	.82	86.4	25.3	7.70	.56	.69	.84	81.6	23.9	8.54	.57	.71	.87
	3000	1415	99.4	29.1	6.38	.58	.71	.88	95.0	27.8	7.04	.59	.73	.91	90.1	26.4	7.79	.59	.76	.94	84.7	24.8	8.63	.61	.78	.98
	3600	1700	102.3	30.0	6.45	.60	.77	.96	97.7	28.6	7.10	.62	.80	.99	92.6	27.1	7.85	.63	.83	1.00	87.0	25.5	8.70	.64	.86	1.00
71°F (22°C)	2400	1135	100.6	29.5	6.41	.42	.53	.64	96.1	28.2	7.06	.42	.54	.65	91.1	26.7	7.81	.42	.54	.67	86.4	25.3	8.68	.42	.56	.69
	3000	1415	105.0	30.8	6.51	.43	.56	.69	100.2	29.4	7.17	.43	.57	.71	95.0	27.8	7.91	.43	.58	.73	89.6	26.3	8.77	.44	.60	.76
	3600	1700	108.0	31.7	6.58	.44	.59	.75	103.0	30.2	7.24	.45	.61	.77	97.6	28.6	7.98	.45	.62	.80	91.9	26.9	8.83	.46	.64	.83

**BLOWER DATA - DIRECT DRIVE****2 - 2.5 TON**

Blower tables include resistance for base unit with standard heat, wet indoor coil, & 2 in. disposable air filters in place.

FOR ALL UNITS ADD:

- 1 - Any factory installed options air resistance (larger gas heat section, economizer, etc.) See page 25.
- 2 - Any field installed accessories air resistance (duct resistance, diffuser, etc.) See page 25.

External Static Pressure (in. w.g.)	Air Volume (cfm) at Various Blower Speeds					
	208 VOLTS			230 VOLTS		
	High	Medium	Low	High	Medium	Low
<b>2 and 2.5 Ton Standard Efficiency (Downflow)</b>				<b>KGA024S and KGA030S</b>		
0.0	1255	985	860	1420	1150	920
0.1	1240	965	830	1410	1120	910
0.2	1225	940	790	1400	1095	890
0.3	1210	910	745	1390	1065	860
0.4	1185	870	695	1365	1030	820
0.5	1150	825	---	1335	985	770
0.6	1100	775	---	1280	935	715
0.7	1035	715	---	1210	865	---
0.8	940	---	---	1115	780	---
0.9	815	---	---	990	---	---
1.0	---	---	---	830	---	---
<b>2 and 2.5 Ton Standard Efficiency (Horizontal)</b>				<b>KGA024S and KGA030S</b>		
0.0	1190	935	815	1345	1090	875
0.1	1175	915	785	1335	1065	865
0.2	1160	890	750	1330	1035	845
0.3	1145	860	705	1315	1010	815
0.4	1125	825	660	1295	975	775
0.5	1090	785	---	1265	935	730
0.6	1045	735	---	1215	885	675
0.7	980	680	---	1150	820	---
0.8	890	---	---	1055	740	---
0.9	775	---	---	935	---	---
1.0	---	---	---	785	---	---

**BLOWER DATA - DIRECT DRIVE**

**3 - 4 TON**

Blower tables include resistance for base unit with standard heat, wet indoor coil, & 2 in. disposable air filters in place.

FOR ALL UNITS ADD:

- 1 - Any factory installed options air resistance (larger gas heat section, economizer, etc.) See page 25.
- 2 - Any field installed accessories air resistance (duct resistance, diffuser, etc.) See page 25.

External Static Pressure (in. w.g.)	Air Volume (cfm) at Various Blower Speeds								
	208 VOLTS			230 VOLTS			460/575 VOLTS		
	High	Medium	Low	High	Medium	Low	High	Medium	Low
<b>3 and 4 Ton Standard Efficiency (Downflow)</b>					<b>KGA036S and KGA048S</b>				
0.0	1965	1640	1150	2145	1845	1330	2070	1755	1220
0.1	1905	1595	1150	2070	1785	1325	2020	1700	1220
0.2	1855	1545	1130	2010	1735	1300	1970	1645	1205
0.3	1810	1500	1095	1955	1680	1260	1920	1595	1180
0.4	1755	1455	1035	1895	1625	1200	1865	1545	1135
0.5	1690	1405	965	1830	1570	1130	1795	1495	1075
0.6	1610	1350	875	1745	1510	1045	1715	1450	1000
0.7	1515	1290	775	1635	1445	945	1615	1410	910
0.8	1385	1220	---	1490	1370	---	1490	1375	---
0.9	1225	1150	---	1310	1290	---	1340	1360	---
1.0	1025	---	---	1075	---	---	1150	---	---
<b>3 and 4 Ton Standard Efficiency (Horizontal)</b>					<b>KGA036S and KGA048S</b>				
0.0	1860	1565	1095	2030	1755	1265	2055	1765	1260
0.1	1805	1510	1090	1960	1695	1255	1990	1700	1245
0.2	1755	1465	1075	1900	1640	1235	1935	1640	1230
0.3	1710	1420	1035	1850	1585	1195	1875	1590	1200
0.4	1660	1370	985	1790	1535	1140	1815	1545	1160
0.5	1595	1320	910	1720	1475	1070	1745	1495	1095
0.6	1510	1260	825	1630	1410	980	1660	1440	1005
0.7	1400	1190	720	1510	1330	880	1555	1375	885
0.8	1255	1100	---	1350	1230	---	1425	1295	---
0.9	1065	990	---	1140	1110	---	1260	1200	---
1.0	830	---	---	875	---	---	1055	---	---

**BLOWER DATA - DIRECT DRIVE****5 TON**

Blower tables include resistance for base unit with standard heat, wet indoor coil, &amp; 2 in. disposable air filters in place.

FOR ALL UNITS ADD:

1 - Any factory installed options air resistance (larger gas heat section, economizer, etc.) See page 25.

2 - Any field installed accessories air resistance (duct resistance, diffuser, etc.) See page 25.

External Static Pressure (in. w.g.)	Air Volume (cfm) at Various Blower Speeds					
	208 VOLTS		230 VOLTS		460/575 VOLTS	
	High	Low	High	Low	High	Low
<b>5 Ton Standard Efficiency (Downflow)</b>						<b>KGA060S</b>
0.0	2230	1670	2410	1950	2240	1730
0.1	2205	1680	2380	1945	2175	1725
0.2	2175	1685	2350	1930	2130	1725
0.3	2145	1685	2315	1915	2095	1725
0.4	2110	1670	2270	1890	2070	1720
0.5	2065	1650	2215	1860	2040	1705
0.6	2015	1615	2155	1815	2010	1675
0.7	1950	1565	2085	1755	1960	1630
0.8	1875	1495	2000	1685	1900	1560
0.9	1780	1410	1900	1595	1810	1465
1.0	1675	---	1785	---	1690	---
<b>5 Ton Standard Efficiency (Horizontal)</b>						<b>KGA060S</b>
0.0	2110	1615	2280	1885	2305	1815
0.1	2075	1625	2245	1880	2260	1825
0.2	2040	1625	2205	1860	2215	1820
0.3	2000	1610	2155	1835	2170	1805
0.4	1950	1590	2100	1800	2120	1775
0.5	1900	1555	2040	1750	2065	1735
0.6	1835	1505	1965	1695	2005	1680
0.7	1765	1450	1890	1625	1935	1615
0.8	1685	1375	1800	1545	1855	1535
0.9	1595	1295	1700	1460	1755	1445
1.0	1495	---	1595	---	1645	---

**BLOWER DATA - BELT DRIVE**

**3 TON**

Blower tables include resistance for base unit with standard heat, wet indoor coil, & 2 in. disposable air filters in place.

FOR ALL UNITS ADD:

- 1 - Any factory installed options air resistance (larger gas heat section, economizer, etc.) See page 25.
- 2 - Any field installed accessories air resistance (duct resistance, diffuser, etc.) See page 25.

Then determine from table the blower motor output and drive required.

**0.10 to 1.00 in. w.g.**

**3 Ton Standard Efficiency (Downflow)**

**KGA036S**

Air Volume (cfm)	External Static (in.w.g.)															
	0.10		0.20		0.30		0.40		0.50		0.60		0.70		0.80	
	RPM	BHP	RPM	BHP	RPM	BHP	RPM	BHP	RPM	BHP	RPM	BHP	RPM	BHP	RPM	BHP
	<b>Field Furnished</b>				<b>Low Static - Drive Kit A01</b>										<b>Kit A05</b>	
900	500	0.10	605	0.15	705	0.25	790	0.30	870	0.40	945	0.50	1010	0.60	1075	0.75
1000	535	0.15	630	0.20	720	0.25	805	0.35	885	0.45	955	0.55	1020	0.65	1085	0.80
1100	570	0.15	655	0.20	740	0.30	820	0.40	895	0.45	970	0.60	1035	0.70	1095	0.80
1200	605	0.20	685	0.25	765	0.35	840	0.40	915	0.50	980	0.60	1045	0.75	1110	0.85
1300	640	0.25	715	0.30	790	0.35	865	0.45	930	0.55	1000	0.65	1060	0.80	1120	0.90
1400	680	0.30	750	0.35	820	0.45	885	0.50	955	0.60	1015	0.70	1080	0.85	1135	0.95
1500	720	0.35	785	0.40	850	0.50	910	0.55	975	0.65	1035	0.80	1095	0.90	1155	1.05

**0.90 to 1.60 in. w.g.**

**3 Ton Standard Efficiency (Downflow)**

**KGA036S**

Air Volume (cfm)	External Static (in.w.g.)															
	0.90		1.0		1.10		1.20		1.30		1.40		1.50		1.60	
	RPM	BHP	RPM	BHP	RPM	BHP	RPM	BHP	RPM	BHP	RPM	BHP	RPM	BHP	RPM	BHP
	<b>High Static - A05</b>										<b>Field Furnished</b>					
900	1135	0.85	1190	1.00	1245	1.10	1295	1.25	1345	1.40	1390	1.55	1435	1.70	1480	1.85
1000	1145	0.90	1200	1.05	1255	1.15	1305	1.30	1355	1.45	1400	1.60	1445	1.75	1490	1.90
1100	1155	0.95	1210	1.10	1265	1.20	1315	1.35	1365	1.50	1410	1.65	1455	1.80	1500	1.95
1200	1165	1.00	1225	1.15	1275	1.25	1325	1.40	1375	1.55	1425	1.75	1470	1.90	1510	2.05
1300	1180	1.05	1235	1.20	1285	1.30	1340	1.50	1385	1.65	1435	1.80	1480	1.95	1525	2.15
1400	1195	1.10	1245	1.25	1300	1.40	1350	1.55	1400	1.70	1445	1.85	1490	2.05	1535	2.20
1500	1210	1.15	1260	1.30	1315	1.45	1360	1.60	1410	1.75	1455	1.95	1500	2.10	1545	2.30

**0.10 to 0.80 in. w.g.**

**3 Ton Standard Efficiency (Horizontal)**

**KGA036S**

Air Volume (cfm)	External Static (in.w.g.)															
	0.10		0.20		0.30		0.40		0.50		0.60		0.70		0.80	
	RPM	BHP	RPM	BHP	RPM	BHP	RPM	BHP	RPM	BHP	RPM	BHP	RPM	BHP	RPM	BHP
	<b>Field Furnished</b>				<b>Low Static - Drive Kit A01</b>											
900	490	0.10	580	0.15	665	0.20	745	0.25	815	0.30	880	0.40	940	0.45	1000	0.55
1000	525	0.10	610	0.15	690	0.25	760	0.30	830	0.35	895	0.45	955	0.50	1010	0.60
1100	560	0.15	640	0.20	710	0.25	780	0.30	850	0.40	910	0.45	970	0.55	1025	0.65
1200	600	0.20	670	0.25	740	0.30	805	0.35	870	0.45	930	0.50	985	0.60	1040	0.70
1300	635	0.25	705	0.30	770	0.35	830	0.40	890	0.50	950	0.55	1005	0.65	1055	0.75
1400	675	0.30	740	0.35	800	0.40	860	0.50	915	0.55	970	0.65	1025	0.70	1075	0.80
1500	715	0.35	775	0.40	830	0.45	885	0.55	940	0.60	995	0.70	1045	0.80	1095	0.90

**0.90 to 1.60 in. w.g.**

**3 Ton Standard Efficiency (Horizontal)**

**KGA036S**

Air Volume (cfm)	External Static (in.w.g.)															
	0.90		1.0		1.10		1.20		1.30		1.40		1.50		1.60	
	RPM	BHP	RPM	BHP	RPM	BHP	RPM	BHP	RPM	BHP	RPM	BHP	RPM	BHP	RPM	BHP
	<b>High Static - A05</b>										<b>Field</b>					
900	1055	0.60	1105	0.70	1155	0.80	1205	0.90	1250	0.95	1295	1.05	1335	1.15	1375	1.25
1000	1065	0.65	1115	0.75	1165	0.85	1215	0.95	1260	1.05	1305	1.15	1345	1.20	1385	1.30
1100	1080	0.70	1130	0.80	1175	0.90	1225	1.00	1270	1.10	1315	1.20	1355	1.30	1395	1.40
1200	1090	0.75	1140	0.85	1190	0.95	1235	1.05	1280	1.15	1325	1.25	1365	1.35	1405	1.45
1300	1105	0.80	1155	0.90	1205	1.00	1250	1.10	1295	1.25	1335	1.35	1375	1.45	1415	1.55
1400	1125	0.90	1170	1.00	1220	1.10	1265	1.20	1305	1.30	1350	1.40	1390	1.50	1430	1.65
1500	1145	1.00	1190	1.05	1235	1.15	1280	1.30	1320	1.40	1365	1.50	1405	1.60	1440	1.70

**BLOWER DATA - BELT DRIVE**

**4 TON**

Blower tables include resistance for base unit with standard heat, **wet indoor coil**, & 2 in. disposable air filters in place.

FOR ALL UNITS ADD:

1 - Any factory installed options air resistance (larger gas heat section, economizer, etc.) See page 25.

2 - Any field installed accessories air resistance (duct resistance, diffuser, etc.) See page 25.

Then determine from table the blower motor output and drive required.

**0.10 to 0.80 in. w.g. 4 Ton Standard Efficiency (Downflow) KGA048S**

Air Volume (cfm)	External Static (in.w.g.)															
	0.10		0.20		0.30		0.40		0.50		0.60		0.70		0.80	
	RPM	BHP	RPM	BHP	RPM	BHP	RPM	BHP	RPM	BHP	RPM	BHP	RPM	BHP	RPM	BHP
	<b>Field Furnished</b>				<b>Low Static - Drive Kit A02</b>											
1200	600	0.20	680	0.25	755	0.30	830	0.35	900	0.45	965	0.55	1025	0.65	1085	0.75
1300	640	0.20	710	0.25	780	0.35	850	0.40	915	0.50	980	0.60	1040	0.70	1100	0.80
1400	675	0.25	745	0.30	810	0.40	875	0.45	940	0.55	1000	0.65	1060	0.75	1115	0.85
1500	715	0.30	780	0.35	840	0.45	900	0.50	960	0.60	1020	0.70	1080	0.80	1135	0.90
1600	755	0.35	815	0.45	870	0.50	930	0.60	985	0.65	1045	0.75	1100	0.85	1150	0.95
1700	795	0.45	850	0.50	905	0.55	960	0.65	1015	0.75	1070	0.85	1120	0.95	1170	1.05
1800	835	0.50	885	0.60	940	0.65	990	0.75	1045	0.80	1095	0.90	1145	1.00	1195	1.15
1900	880	0.60	925	0.65	975	0.75	1025	0.80	1075	0.90	1120	1.00	1170	1.10	1220	1.20
2000	920	0.70	965	0.75	1010	0.85	1055	0.90	1105	1.00	1150	1.10	1195	1.20	1245	1.35

**0.90 to 1.60 in. w.g. 4 Ton Standard Efficiency (Downflow) KGA048S**

Air Volume (cfm)	External Static (in.w.g.)															
	0.90		1.00		1.10		1.20		1.30		1.40		1.50		1.60	
	RPM	BHP	RPM	BHP	RPM	BHP	RPM	BHP	RPM	BHP	RPM	BHP	RPM	BHP	RPM	BHP
	<b>High Static - A06</b>												<b>Field Furnished</b>			
1200	1140	0.85	1195	0.95	1245	1.05	1295	1.20	1340	1.30	1385	1.40	1430	1.55	1470	1.65
1300	1155	0.90	1205	1.00	1260	1.10	1305	1.25	1350	1.35	1395	1.50	1440	1.60	1480	1.75
1400	1170	0.95	1220	1.05	1270	1.15	1320	1.30	1365	1.40	1410	1.55	1455	1.70	1495	1.80
1500	1185	1.00	1235	1.10	1285	1.25	1335	1.35	1380	1.50	1425	1.65	1465	1.75	1510	1.90
1600	1205	1.10	1255	1.20	1300	1.30	1350	1.45	1395	1.60	1435	1.70	1480	1.85	1520	2.00
1700	1220	1.15	1270	1.25	1320	1.40	1365	1.55	1410	1.65	1450	1.80	1495	1.95	1535	2.05
1800	1245	1.25	1290	1.35	1335	1.50	1380	1.60	1425	1.75	1465	1.90	1510	2.05	1550	2.15
1900	1265	1.35	1310	1.45	1355	1.60	1400	1.70	1440	1.85	1485	2.00	1525	2.15	1565	2.30
2000	1290	1.45	1330	1.55	1375	1.70	1420	1.80	1460	1.95	1500	2.10	1540	2.25	1580	2.40

**0.10 to 0.80 in. w.g. 4 Ton Standard Efficiency (Horizontal) KGA048S**

Air Volume (cfm)	External Static (in.w.g.)															
	0.10		0.20		0.30		0.40		0.50		0.60		0.70		0.80	
	RPM	BHP	RPM	BHP	RPM	BHP	RPM	BHP	RPM	BHP	RPM	BHP	RPM	BHP	RPM	BHP
	<b>Field Furnished</b>				<b>Low Static - Drive Kit A02</b>											
1200	590	0.20	665	0.25	735	0.30	805	0.35	870	0.40	930	0.50	990	0.55	1050	0.65
1300	630	0.20	695	0.25	760	0.35	825	0.40	890	0.45	950	0.55	1010	0.65	1065	0.70
1400	670	0.25	730	0.30	790	0.40	850	0.45	910	0.50	970	0.60	1025	0.70	1080	0.75
1500	710	0.35	765	0.40	820	0.45	880	0.50	935	0.60	990	0.65	1045	0.75	1095	0.85
1600	750	0.40	800	0.45	855	0.50	910	0.60	960	0.65	1015	0.75	1065	0.80	1115	0.90
1700	790	0.45	840	0.50	890	0.60	940	0.65	990	0.75	1040	0.80	1090	0.90	1135	1.00
1800	830	0.55	875	0.60	925	0.65	970	0.75	1020	0.80	1065	0.90	1115	1.00	1160	1.10
1900	870	0.65	915	0.70	960	0.75	1005	0.85	1050	0.90	1095	1.00	1140	1.10	1185	1.20
2000	915	0.75	955	0.80	995	0.85	1040	0.95	1080	1.00	1125	1.10	1165	1.20	1210	1.30

**0.90 to 1.60 in. w.g. 4 Ton Standard Efficiency (Horizontal) KGA048S**

Air Volume (cfm)	External Static (in.w.g.)															
	0.90		1.0		1.10		1.20		1.30		1.40		1.50		1.60	
	RPM	BHP	RPM	BHP	RPM	BHP	RPM	BHP	RPM	BHP	RPM	BHP	RPM	BHP	RPM	BHP
	<b>Kit #2</b>												<b>High Static - A06</b>			
1200	1105	0.75	1155	0.85	1205	0.95	1255	1.05	1300	1.15	1340	1.25	1385	1.35	1425	1.45
1300	1115	0.80	1165	0.90	1215	1.00	1265	1.10	1310	1.20	1355	1.30	1395	1.40	1435	1.55
1400	1130	0.85	1180	0.95	1230	1.05	1275	1.15	1320	1.25	1365	1.40	1405	1.50	1450	1.60
1500	1145	0.90	1195	1.00	1245	1.15	1290	1.25	1335	1.35	1375	1.45	1420	1.55	1460	1.70
1600	1165	1.00	1210	1.10	1260	1.20	1305	1.30	1345	1.40	1390	1.55	1430	1.65	1470	1.75
1700	1185	1.10	1230	1.20	1275	1.30	1320	1.40	1360	1.50	1405	1.60	1445	1.75	1485	1.85
1800	1205	1.15	1250	1.25	1295	1.40	1335	1.50	1380	1.60	1420	1.70	1460	1.85	1500	1.95
1900	1225	1.25	1270	1.35	1315	1.50	1355	1.60	1395	1.70	1435	1.80	1475	1.95	1515	2.10
2000	1250	1.40	1295	1.50	1335	1.60	1375	1.70	1415	1.80	1455	1.95	1490	2.05	1530	2.20

**BLOWER DATA - BELT DRIVE**

**5 TON**

Blower tables include resistance for base unit with standard heat, **wet indoor coil**, & 2 in. disposable air filters in place.

FOR ALL UNITS ADD:

1 - Any factory installed options air resistance (larger gas heat section, economizer, etc.) See page 25.

2 - Any field installed accessories air resistance (duct resistance, diffuser, etc.) See page 25.

Then determine from table the blower motor output and drive required.

**0.10 to 0.80 in. w.g. 5 Ton Standard Efficiency (Downflow) KGA060S**

Air Volume (cfm)	External Static (in.w.g.)															
	0.10		0.20		0.30		0.40		0.50		0.60		0.70		0.80	
	RPM	BHP	RPM	BHP	RPM	BHP	RPM	BHP	RPM	BHP	RPM	BHP	RPM	BHP	RPM	BHP
	<b>Field Furnished</b>				<b>Low Static - Drive Kit A03</b>											
1600	765	0.35	820	0.40	870	0.45	925	0.55	975	0.60	1025	0.65	1075	0.70	1120	0.80
1700	805	0.45	855	0.50	905	0.55	955	0.60	1005	0.65	1055	0.75	1100	0.80	1145	0.85
1800	850	0.50	895	0.55	945	0.60	990	0.70	1035	0.75	1080	0.80	1125	0.90	1170	0.95
1900	890	0.60	935	0.65	980	0.70	1025	0.75	1070	0.85	1115	0.90	1155	1.00	1200	1.05
2000	935	0.70	975	0.75	1020	0.80	1060	0.85	1100	0.95	1145	1.00	1185	1.10	1225	1.15
2100	975	0.80	1015	0.85	1055	0.90	1095	0.95	1135	1.05	1175	1.10	1215	1.20	1255	1.25
2200	1020	0.90	1055	0.95	1095	1.00	1135	1.10	1170	1.15	1210	1.25	1250	1.30	1285	1.40
2300	1060	1.00	1095	1.10	1135	1.15	1170	1.20	1210	1.30	1245	1.35	1280	1.45	1320	1.55
2400	1105	1.15	1140	1.20	1175	1.30	1210	1.35	1245	1.45	1280	1.50	1315	1.60	1350	1.70

**0.90 to 1.60 in. w.g. 5 Ton Standard Efficiency (Downflow) KGA060S**

Air Volume (cfm)	External Static (in.w.g.)															
	0.90		1.00		1.10		1.20		1.30		1.40		1.50		1.60	
	RPM	BHP	RPM	BHP	RPM	BHP	RPM	BHP	RPM	BHP	RPM	BHP	RPM	BHP	RPM	BHP
	<b>Low Static - A03</b>				<b>High Static - A07</b>											
1600	1165	0.85	1210	0.95	1255	1.05	1295	1.10	1335	1.20	1375	1.30	1415	1.35	1450	1.45
1700	1190	0.95	1235	1.05	1275	1.10	1315	1.20	1355	1.30	1395	1.35	1430	1.45	1470	1.55
1800	1215	1.05	1255	1.10	1295	1.20	1335	1.30	1375	1.40	1415	1.45	1450	1.55	1485	1.65
1900	1240	1.15	1280	1.20	1320	1.30	1360	1.40	1395	1.50	1435	1.60	1470	1.65	1505	1.75
2000	1265	1.25	1305	1.30	1345	1.40	1380	1.50	1420	1.60	1455	1.70	1490	1.80	1525	1.90
2100	1295	1.35	1335	1.45	1370	1.55	1405	1.60	1445	1.70	1480	1.80	1515	1.90	1550	2.00
2200	1325	1.50	1360	1.55	1395	1.65	1435	1.75	1470	1.85	1505	1.95	1535	2.05	1570	2.15
2300	1355	1.60	1390	1.70	1425	1.80	1460	1.90	1495	2.00	1530	2.10	1560	2.20	1595	2.30
2400	1385	1.75	1420	1.85	1455	1.95	1490	2.05	1520	2.15	1555	2.25	1585	2.35	1620	2.45

**0.10 to 0.80 in. w.g. 5 Ton Standard Efficiency (Horizontal) KGA060S**

Air Volume (cfm)	External Static (in.w.g.)															
	0.10		0.20		0.30		0.40		0.50		0.60		0.70		0.80	
	RPM	BHP	RPM	BHP	RPM	BHP	RPM	BHP	RPM	BHP	RPM	BHP	RPM	BHP	RPM	BHP
	<b>Field Furnished</b>				<b>Low Static - Drive Kit A03</b>											
1600	750	0.35	805	0.40	865	0.50	925	0.55	980	0.65	1040	0.75	1095	0.85	1150	0.95
1700	790	0.45	845	0.50	900	0.55	955	0.65	1010	0.75	1065	0.80	1115	0.90	1170	1.05
1800	830	0.50	880	0.55	930	0.65	985	0.70	1035	0.80	1090	0.90	1140	1.00	1190	1.10
1900	870	0.60	920	0.65	965	0.75	1015	0.80	1065	0.90	1115	1.00	1165	1.10	1210	1.20
2000	910	0.70	955	0.75	1005	0.85	1050	0.90	1095	1.00	1145	1.10	1190	1.20	1235	1.30
2100	955	0.80	995	0.85	1040	0.95	1085	1.00	1130	1.10	1175	1.20	1220	1.30	1260	1.40
2200	995	0.90	1035	0.95	1075	1.05	1120	1.15	1160	1.20	1205	1.30	1245	1.40	1290	1.55
2300	1035	1.00	1075	1.10	1115	1.15	1155	1.25	1195	1.35	1235	1.45	1275	1.55	1320	1.65
2400	1080	1.15	1115	1.25	1155	1.30	1190	1.40	1230	1.50	1270	1.60	1310	1.70	1345	1.80

**0.90 to 1.60 in. w.g. 5 Ton Standard Efficiency (Horizontal) KGA060S**

Air Volume (cfm)	External Static (in.w.g.)															
	0.90		1.00		1.10		1.20		1.30		1.40		1.50		1.60	
	RPM	BHP	RPM	BHP	RPM	BHP	RPM	BHP	RPM	BHP	RPM	BHP	RPM	BHP	RPM	BHP
	<b>Drive Kit #3</b>				<b>High Static - A07</b>											
1600	1200	1.05	1250	1.20	1300	1.30	1350	1.45	1395	1.55	1440	1.70	1485	1.85	1525	2.00
1700	1220	1.15	1270	1.25	1315	1.40	1365	1.50	1410	1.65	1455	1.80	1495	1.90	1540	2.10
1800	1240	1.20	1285	1.35	1335	1.45	1380	1.60	1425	1.75	1470	1.90	1510	2.00	1550	2.15
1900	1260	1.30	1305	1.45	1350	1.55	1395	1.70	1440	1.85	1485	1.95	1525	2.10	1565	2.25
2000	1280	1.40	1325	1.55	1370	1.65	1415	1.80	1455	1.90	1500	2.05	1540	2.20	1580	2.35
2100	1305	1.50	1350	1.65	1390	1.75	1435	1.90	1475	2.05	1515	2.20	1555	2.30	1595	2.50
2200	1330	1.65	1375	1.75	1415	1.90	1455	2.00	1495	2.15	1535	2.30	1575	2.45	1615	2.60
2300	1360	1.80	1400	1.90	1440	2.05	1480	2.15	1515	2.30	1555	2.45	1595	2.60	1630	2.75
2400	1385	1.90	1425	2.05	1465	2.20	1500	2.30	1540	2.45	1580	2.60	1615	2.75	1650	2.90

**BLOWER DATA - BELT DRIVE**

**6 TON**

Blower tables include resistance for base unit with standard heat, **wet indoor coil**, & 2 in. disposable air filters in place.

FOR ALL UNITS ADD:

1 - Any factory installed options air resistance (larger gas heat section, economizer, etc.) See page 25.

2 - Any field installed accessories air resistance (duct resistance, diffuser, etc.) See page 25.

Then determine from table the blower motor output and drive required.

**0.10 to 0.80 in. w.g.**

**6 Ton Standard Efficiency (Downflow)**

**KGA072S**

Air Volume (cfm)	External Static (in.w.g.)															
	0.10		0.20		0.30		0.40		0.50		0.60		0.70		0.80	
	RPM	BHP	RPM	BHP	RPM	BHP	RPM	BHP	RPM	BHP	RPM	BHP	RPM	BHP	RPM	BHP
	<b>Field Furnished</b>						<b>Low Static - Drive Kit A04</b>									
1900	855	0.48	901	0.53	947	0.57	998	0.63	1043	0.67	1089	0.72	1134	0.77	1174	0.82
2000	892	0.58	938	0.58	984	0.63	1030	0.67	1076	0.78	1121	0.82	1161	0.88	1201	0.93
2100	935	0.64	981	0.68	1021	0.73	1067	0.78	1107	0.83	1152	0.87	1192	0.98	1232	1.03
2200	976	0.73	1017	0.78	1064	0.84	1104	0.89	1145	0.93	1185	0.98	1224	1.08	1258	1.13
2300	1019	0.83	1060	0.88	1101	0.94	1141	0.98	1176	1.03	1216	1.08	1255	1.19	1290	1.24
2400	1062	0.94	1102	0.99	1137	1.04	1178	1.09	1213	1.14	1252	1.24	1286	1.29	1321	1.34
2500	1104	1.04	1139	1.09	1180	1.14	1215	1.19	1249	1.29	1284	1.34	1318	1.39	1352	1.50
2600	1146	1.15	1182	1.24	1216	1.30	1251	1.34	1286	1.40	1320	1.50	1353	1.56	1383	1.61
2700	1189	1.30	1224	1.35	1258	1.40	1288	1.50	1322	1.55	1356	1.60	1384	1.71	1418	1.76
2800	1231	1.46	1265	1.51	1295	1.56	1329	1.66	1357	1.72	1392	1.76	1420	1.87	1450	1.91
2900	1273	1.61	1307	1.66	1335	1.72	1365	1.81	1393	1.87	1427	1.97	1456	2.02	1485	2.07

**0.90 to 1.60 in. w.g.**

**6 Ton Standard Efficiency (Downflow)**

**KGA072S**

Air Volume (cfm)	External Static (in.w.g.)															
	0.90		1.00		1.10		1.20		1.30		1.40		1.50		1.60	
	RPM	BHP	RPM	BHP	RPM	BHP	RPM	BHP	RPM	BHP	RPM	BHP	RPM	BHP	RPM	BHP
	<b>Low Static - Drive Kit A04</b>						<b>High Static - A08</b>									
1900	1219	0.92	1258	0.97	1297	1.02	1336	1.07	1372	1.17	1413	1.23	1448	1.28	1484	1.38
2000	1245	0.97	1284	1.07	1319	1.13	1358	1.17	1393	1.22	1429	1.33	1470	1.38	1505	1.48
2100	1271	1.07	1306	1.13	1345	1.23	1380	1.28	1420	1.38	1456	1.43	1492	1.48	1522	1.59
2200	1298	1.18	1331	1.23	1371	1.33	1406	1.38	1441	1.49	1477	1.53	1513	1.63	1548	1.68
2300	1329	1.29	1362	1.38	1397	1.44	1433	1.48	1468	1.59	1504	1.63	1535	1.73	1570	1.79
2400	1354	1.39	1389	1.49	1424	1.54	1458	1.64	1494	1.69	1525	1.79	1561	1.84	1591	1.94
2500	1386	1.55	1420	1.60	1455	1.70	1485	1.74	1521	1.84	1552	1.89	1587	1.99	1618	2.09
2600	1417	1.70	1451	1.75	1481	1.84	1517	1.89	1547	1.99	1578	2.05	1614	2.14	1645	2.24
2700	1447	1.85	1482	1.90	1512	1.99	1543	2.04	1578	2.14	1610	2.19	1640	2.29	1670	2.39
2800	1484	2.01	1513	2.06	1543	2.15	1574	2.20	1604	2.29	1635	2.40	1666	2.45	1697	2.54
2900	1515	2.16	1544	2.21	1575	2.30	1605	2.39	1636	2.44	1667	2.55	1693	2.64	1723	2.69

## BLOWER DATA - BELT DRIVE

**6 TON**

Blower tables include resistance for base unit with standard heat, **wet indoor coil**, & 2 in. disposable air filters in place.

FOR ALL UNITS ADD:

1 - Any factory installed options air resistance (larger gas heat section, economizer, etc.) See page 25.

2 - Any field installed accessories air resistance (duct resistance, diffuser, etc.) See page 25.

Then determine from table the blower motor output and drive required.

0.10 to 0.80 in. w.g.

6 Ton Standard Efficiency (Horizontal)

KGA072S

Air Volume (cfm)	External Static (in.w.g.)															
	0.10		0.20		0.30		0.40		0.50		0.60		0.70		0.80	
	RPM	BHP	RPM	BHP	RPM	BHP	RPM	BHP	RPM	BHP	RPM	BHP	RPM	BHP	RPM	BHP
	<b>Field Furnished</b>						<b>Low Static - Drive Kit A04</b>									
1900	810	0.48	866	0.58	922	0.62	978	0.73	1028	0.77	1079	0.87	1129	0.92	1179	1.02
2000	852	0.58	903	0.63	954	0.73	1005	0.77	1056	0.88	1106	0.92	1156	1.03	1201	1.13
2100	890	0.69	941	0.73	991	0.78	1037	0.88	1087	0.93	1132	1.02	1182	1.13	1227	1.23
2200	926	0.73	977	0.83	1024	0.89	1069	0.99	1120	1.03	1165	1.13	1209	1.23	1248	1.33
2300	969	0.83	1015	0.93	1061	0.99	1106	1.08	1146	1.13	1191	1.23	1235	1.34	1275	1.44
2400	1007	0.94	1052	1.04	1092	1.09	1138	1.19	1178	1.29	1222	1.34	1261	1.44	1301	1.54
2500	1049	1.09	1089	1.14	1130	1.24	1170	1.29	1209	1.39	1254	1.49	1293	1.59	1332	1.70
2600	1086	1.20	1127	1.29	1166	1.35	1206	1.44	1246	1.55	1285	1.65	1318	1.71	1358	1.86
2700	1129	1.35	1164	1.40	1203	1.50	1243	1.60	1277	1.65	1316	1.75	1349	1.86	1388	2.01
2800	1166	1.51	1205	1.56	1240	1.66	1274	1.76	1312	1.87	1347	1.91	1380	2.02	1415	2.11
2900	1208	1.66	1242	1.71	1275	1.82	1310	1.91	1343	2.02	1377	2.12	1411	2.22	1445	2.32

0.90 to 1.60 in. w.g.

6 Ton Standard Efficiency (Horizontal)

KGA072S

Air Volume (cfm)	External Static (in.w.g.)															
	0.90		1.00		1.10		1.20		1.30		1.40		1.50		1.60	
	RPM	BHP	RPM	BHP	RPM	BHP	RPM	BHP	RPM	BHP	RPM	BHP	RPM	BHP	RPM	BHP
	<b>Low Static - Drive Kit A04</b>						<b>High Static - A08</b>									
1900	1224	1.12	1268	1.22	1312	1.32	1356	1.47	1397	1.57	1438	1.68	1478	1.78	1519	1.93
2000	1245	1.22	1289	1.32	1334	1.43	1373	1.52	1418	1.67	1459	1.78	1495	1.88	1535	2.03
2100	1271	1.32	1311	1.43	1355	1.53	1395	1.63	1435	1.78	1476	1.88	1517	2.03	1552	2.14
2200	1293	1.43	1331	1.53	1376	1.63	1416	1.78	1456	1.89	1497	1.98	1533	2.13	1573	2.23
2300	1319	1.54	1357	1.63	1397	1.74	1438	1.88	1478	1.99	1514	2.08	1555	2.23	1590	2.39
2400	1344	1.69	1379	1.79	1419	1.89	1458	1.99	1499	2.14	1535	2.24	1571	2.34	1611	2.49
2500	1371	1.80	1405	1.90	1445	2.05	1480	2.14	1521	2.24	1557	2.39	1592	2.49	1628	2.64
2600	1397	1.95	1431	2.05	1471	2.14	1507	2.29	1542	2.39	1578	2.55	1614	2.64	1650	2.79
2700	1422	2.10	1457	2.20	1497	2.29	1533	2.44	1568	2.54	1605	2.69	1640	2.79	1670	2.94
2800	1454	2.26	1488	2.36	1523	2.50	1559	2.60	1594	2.74	1625	2.85	1661	3.00	1697	3.09
2900	1480	2.41	1514	2.51	1550	2.65	1585	2.74	1616	2.89	1652	3.00	1688	3.14	1718	3.29

Note - **BOLD** - to operate in this range, 3 hp blower motor is required.

**BLOWER DATA - BELT DRIVE**

**7.5 TON**

Blower tables include resistance for base unit with medium heat, **dry indoor coil**, & 2 in. disposable air filters in place.

FOR ALL UNITS ADD:

- 1 - Any factory installed options air resistance (high gas heat section, economizer, etc.) See page 25.
- 2 - Any field installed accessories air resistance (duct resistance, diffuser, etc.) See page 25.

Then determine from table the blower motor output and drive required.

**0.10 to 1.00 in. w.g.**

**7.5 Ton Standard Efficiency (Downflow)**

**KGA090S**

Air Volume (cfm)	External Static (in.w.g.)																			
	0.10		0.20		0.30		0.40		0.50		0.60		0.70		0.80		0.90		1.00	
	RPM	BHP	RPM	BHP	RPM	BHP	RPM	BHP	RPM	BHP	RPM	BHP	RPM	BHP	RPM	BHP	RPM	BHP	RPM	BHP
	<b>Ex-Low Static - Drive Kit AA01</b>												<b>Low Static - AA02</b>						<b>MED - AA03</b>	
2400	621	0.71	652	0.76	684	0.81	716	0.86	746	0.92	776	0.97	805	1.02	830	1.08	855	1.14	879	1.19
2500	642	0.77	673	0.82	704	0.87	734	0.93	764	0.98	793	1.04	820	1.09	845	1.15	868	1.21	892	1.27
2600	665	0.82	694	0.88	724	0.93	753	0.99	782	1.05	810	1.11	835	1.17	859	1.23	883	1.29	907	1.34
2700	688	0.89	716	0.94	744	1.00	773	1.06	800	1.13	827	1.19	851	1.25	875	1.31	898	1.37	922	1.42
2800	710	0.95	738	1.02	765	1.08	792	1.15	818	1.21	844	1.28	868	1.34	891	1.40	914	1.45	938	1.51
2900	733	1.03	759	1.10	785	1.17	811	1.24	836	1.30	861	1.37	885	1.43	908	1.49	931	1.54	954	1.59
3000	754	1.12	779	1.19	805	1.26	830	1.33	855	1.40	879	1.46	902	1.52	925	1.58	948	1.63	970	1.69
3100	775	1.22	800	1.29	824	1.36	849	1.43	873	1.50	897	1.56	920	1.62	942	1.67	964	1.73	987	1.78
3200	796	1.32	820	1.39	844	1.47	868	1.53	892	1.60	915	1.66	937	1.72	959	1.77	981	1.83	1002	1.88
3300	816	1.43	840	1.50	863	1.57	887	1.64	910	1.70	933	1.76	955	1.82	976	1.88	997	1.93	1018	1.99
3400	837	1.54	860	1.61	883	1.68	906	1.75	929	1.81	951	1.87	972	1.93	993	1.98	1013	2.05	1033	2.11
3500	858	1.66	881	1.73	903	1.79	926	1.86	948	1.92	969	1.98	990	2.04	1009	2.10	1029	2.17	1048	2.24
3600	879	1.77	901	1.84	923	1.91	945	1.97	966	2.04	987	2.10	1006	2.16	1025	2.23	1044	2.3	1062	2.38

**0.90 to 2.00 in. w.g.**

**7.5 Ton Standard Efficiency (Downflow)**

**KGA090S**

Air Volume (cfm)	External Static (in.w.g.)																			
	1.10		1.20		1.30		1.40		1.50		1.60		1.70		1.80		1.90		2.00	
	RPM	BHP	RPM	BHP	RPM	BHP	RPM	BHP	RPM	BHP	RPM	BHP	RPM	BHP	RPM	BHP	RPM	BHP	RPM	BHP
	<b>Medium Static - AA03</b>																		<b>Hi - AA04</b>	
2400	904	1.25	929	1.29	956	1.34	982	1.39	1008	1.43	1032	1.49	1056	1.55	1078	1.62	1099	1.68	1121	1.75
2500	917	1.32	942	1.37	968	1.41	994	1.46	1020	1.51	1044	1.57	1066	1.64	1088	1.70	1108	1.77	1130	1.84
2600	931	1.39	957	1.44	982	1.49	1008	1.54	1032	1.60	1055	1.66	1077	1.73	1098	1.80	1118	1.87	1139	1.94
2700	946	1.47	971	1.52	996	1.57	1021	1.63	1045	1.69	1067	1.76	1088	1.83	1108	1.91	1127	1.98	1148	2.05
2800	962	1.56	986	1.61	1011	1.66	1034	1.72	1057	1.79	1079	1.86	1099	1.94	1118	2.02	1137	2.09	1158	2.16
2900	978	1.65	1001	1.70	1025	1.75	1048	1.82	1069	1.89	1090	1.98	1109	2.06	1128	2.14	1147	2.22	1167	2.28
3000	993	1.74	1016	1.79	1039	1.86	1061	1.93	1081	2.01	1101	2.10	1120	2.18	1138	2.27	1157	2.34	1177	2.41
3100	1009	1.84	1031	1.90	1052	1.97	1073	2.05	1093	2.13	1112	2.22	1130	2.31	1148	2.40	1167	2.47	1187	2.53
3200	1024	1.94	1045	2.01	1065	2.09	1085	2.17	1104	2.26	1123	2.36	1141	2.45	1159	2.53	1178	2.60	1198	2.66
3300	1038	2.06	1058	2.13	1078	2.22	1097	2.31	1116	2.40	1134	2.49	1152	2.58	1170	2.66	1189	2.73	1209	2.79
3400	1053	2.19	1072	2.27	1091	2.35	1109	2.45	1127	2.54	1145	2.63	1163	2.72	1181	2.79	1200	2.86	1220	2.92
3500	1067	2.32	1085	2.41	1103	2.5	1121	2.59	1138	2.69	1156	2.78	1174	2.85	1192	2.93	1212	2.99	1231	3.05
3600	1081	2.46	1098	2.55	1116	2.64	1133	2.74	1151	2.83	1168	2.91	1186	2.99	1205	3.06	1224	3.12	1243	3.17

**BLOWER DATA - BELT DRIVE**

**7.5 TON**

Blower tables include resistance for base unit with medium heat, **dry indoor coil**, & 2 in. disposable air filters in place.

FOR ALL UNITS ADD:

- 1 - Any factory installed options air resistance (high gas heat section, economizer, etc.) See page 25.
- 2 - Any field installed accessories air resistance (duct resistance, diffuser, etc.) See page 25.

Then determine from table the blower motor output and drive required.

**0.10 to 1.00 in. w.g.**

**7.5 Ton Standard Efficiency (Horizontal)**

**KGA090S**

Air Volume (cfm)	External Static (in.w.g.)																			
	0.10		0.20		0.30		0.40		0.50		0.60		0.70		0.80		0.90		1.00	
	RPM	BHP	RPM	BHP	RPM	BHP	RPM	BHP	RPM	BHP	RPM	BHP	RPM	BHP	RPM	BHP	RPM	BHP	RPM	BHP
	<b>Ex-Low Static - Drive Kit AA01</b>															<b>Low Static - AA02</b>				
2400	572	0.75	602	0.78	633	0.81	664	0.85	695	0.88	725	0.92	755	0.97	784	1.01	811	1.06	836	1.11
2500	591	0.80	620	0.83	650	0.87	680	0.90	711	0.94	740	0.98	769	1.03	797	1.08	823	1.13	847	1.18
2600	610	0.86	639	0.89	668	0.92	697	0.96	727	1.00	755	1.05	783	1.09	810	1.14	835	1.20	859	1.25
2700	630	0.91	658	0.95	686	0.98	715	1.02	743	1.07	771	1.11	798	1.16	824	1.22	848	1.27	872	1.32
2800	650	0.97	677	1.01	705	1.05	732	1.09	760	1.14	787	1.19	813	1.24	838	1.30	861	1.35	885	1.40
2900	670	1.03	697	1.07	724	1.11	750	1.16	777	1.21	803	1.27	828	1.32	852	1.38	876	1.44	898	1.49
3000	691	1.09	717	1.14	743	1.18	769	1.24	794	1.29	819	1.35	844	1.42	868	1.47	890	1.53	913	1.58
3100	712	1.16	737	1.21	762	1.27	787	1.32	812	1.39	836	1.45	860	1.51	883	1.57	906	1.63	928	1.68
3200	732	1.24	756	1.30	781	1.36	805	1.42	829	1.48	853	1.55	876	1.61	899	1.67	921	1.73	943	1.78
3300	752	1.33	776	1.39	799	1.46	823	1.52	847	1.59	870	1.65	893	1.71	916	1.77	937	1.83	959	1.88
3400	772	1.43	795	1.50	818	1.56	842	1.63	865	1.69	888	1.76	910	1.82	932	1.88	953	1.93	974	1.99
3500	792	1.54	815	1.61	838	1.67	861	1.74	883	1.80	906	1.87	928	1.93	949	1.98	970	2.04	990	2.10
3600	812	1.65	834	1.72	857	1.79	880	1.85	902	1.92	924	1.98	945	2.04	966	2.10	986	2.16	1005	2.22

**0.90 to 2.00 in. w.g.**

**7.5 Ton Standard Efficiency (Horizontal)**

**KGA090S**

Air Volume (cfm)	External Static (in.w.g.)																			
	1.10		1.20		1.30		1.40		1.50		1.60		1.70		1.80		1.90		2.00	
	RPM	BHP	RPM	BHP	RPM	BHP	RPM	BHP	RPM	BHP	RPM	BHP	RPM	BHP	RPM	BHP	RPM	BHP	RPM	BHP
	<b>Lo - AA02</b>		<b>Medium Static - AA03</b>																	
2400	861	1.16	886	1.21	911	1.26	937	1.30	963	1.35	988	1.41	1012	1.47	1034	1.53	1055	1.59	1076	1.65
2500	872	1.23	896	1.27	921	1.32	947	1.37	972	1.43	997	1.48	1019	1.55	1041	1.61	1061	1.68	1081	1.74
2600	883	1.30	908	1.35	933	1.40	958	1.45	982	1.50	1006	1.57	1027	1.63	1048	1.70	1068	1.77	1087	1.83
2700	895	1.37	920	1.42	944	1.47	969	1.53	992	1.59	1015	1.65	1036	1.72	1056	1.79	1075	1.86	1094	1.92
2800	908	1.45	932	1.50	956	1.56	980	1.62	1003	1.68	1025	1.75	1045	1.82	1064	1.89	1083	1.96	1102	2.02
2900	922	1.54	945	1.59	969	1.65	992	1.71	1014	1.78	1035	1.85	1055	1.92	1074	2.00	1092	2.07	1111	2.13
3000	936	1.63	959	1.68	982	1.74	1004	1.81	1026	1.88	1046	1.96	1065	2.03	1084	2.11	1102	2.18	1120	2.25
3100	950	1.73	973	1.78	995	1.85	1017	1.91	1037	1.99	1057	2.07	1076	2.15	1094	2.23	1112	2.31	1130	2.38
3200	965	1.83	987	1.89	1008	1.95	1029	2.03	1049	2.11	1068	2.19	1087	2.28	1105	2.36	1123	2.44	1141	2.51
3300	980	1.94	1001	2.00	1022	2.07	1042	2.15	1061	2.23	1080	2.32	1098	2.41	1116	2.50	1134	2.58	1152	2.65
3400	995	2.05	1015	2.12	1035	2.19	1054	2.28	1073	2.37	1092	2.46	1110	2.55	1128	2.64	1145	2.72	1163	2.79
3500	1010	2.17	1029	2.24	1048	2.32	1067	2.41	1086	2.51	1104	2.60	1122	2.70	1139	2.78	1157	2.86	1174	2.93
3600	1024	2.30	1043	2.38	1062	2.46	1080	2.55	1098	2.65	1116	2.75	1133	2.84	1151	2.93	1168	3.01	1186	3.08
			<b>High Static - AA04</b>																	

## BLOWER DATA

### BELT DRIVE KIT SPECIFICATIONS

Model No.	Motor hp		Drive Kits and RPM Range							
	Nominal	Maximum	A01	A02	A03	A04	A05	A06	A07	A08
036-072	1.5	1.72	673 - 1010	745 - 1117	833 - 1250	968 - 1340	897 - 1346	1071 - 1429	1212 - 1548	1193 - 1591
	2	2.3								
Model No.	Motor hp		Drive Kits and RPM Range							
	Nominal	Maximum	AA01	AA02	AA03	AA04				
090	1	1.15	522 - 784	---	---	---				
	2	2.3	---	632 - 875	798 - 1105	---				
	3	3.45	---			921 - 1228				

NOTE - Using total air volume and system static pressure requirements determine from blower performance tables rpm and motor hp required. Maximum usable hp of motors furnished are shown. In Canada, nominal motor hp is also maximum usable motor hp. If motors of comparable hp are used, be sure to keep within the service factor limitations outlined on the motor nameplate.

### POWER EXHAUST FANS PERFORMANCE

Return Air System Static Pressure in. w.g.	Air Volume Exhausted - cfm											
	T1PWRE10A						T1PWRE10N					
	208V			230V, 460V and 575V			208V			230V, 460V and 575V		
	Low	Medium	High	Low	Medium	High	Low	Medium	High	Low	Medium	High
0	1290	1300	1320	1300	1305	1295	3545	3915	4230	3880	4135	4340
0.1	1045	1055	1055	1040	1050	1055	2880	3215	3580	3255	3550	3755
0.2	805	805	815	805	810	810	2290	2665	3055	2710	3010	3240
0.3	580	580	600	595	590	585	1735	2175	2605	2200	2500	2770
0.4	390	405	400	405	400	410	1165	1660	2175	1685	2010	2325
0.5	245	315	215	240	255	300	530	1045	1710	1120	1510	1885
0.6	155	340	35	90	165	290	---	250	1160	470	990	1420
0.7	145	515	---	---	140	400	---	---	470	---	430	915

### OPTIONS / ACCESSORIES AIR RESISTANCE FOR 024-072 MODELS - in. w.g.

Air Volume cfm	Economizer	Gas Heat	
		Medium Input	High Input
800	0.04	0.02	0.02
1000	0.04	0.02	0.02
1200	0.04	0.02	0.02
1400	0.04	0.02	0.03
1600	0.04	0.03	0.04
1800	0.05	0.03	0.05
2000	0.05	0.04	0.06
2200	0.05	0.04	0.07
2400	0.05	0.05	0.08
2600	0.06	0.05	0.09
2800	0.06	0.06	0.10
3000	0.06	0.07	0.11

### OPTIONS / ACCESSORIES AIR RESISTANCE FOR 090 MODELS - in. w.g.

Air Volume cfm	Economizer	Gas Heat	Wet Indoor Coil
		High Input	
2400	0.05	0.03	0.08
2600	0.06	0.04	0.09
2800	0.06	0.04	0.10
3000	0.06	0.04	0.11
3200	0.06	0.04	0.12
3400	0.06	0.05	0.14
3600	0.06	0.05	0.15
3800	0.07	0.05	0.16
4000	0.07	0.06	0.18

## BLOWER DATA

### CEILING DIFFUSERS AIR RESISTANCE (in. w.g.)

Air Volume cfm	RTD9-65 Step-Down Diffuser			FD9-65 Flush Diffuser	RTD11-95 Step-Down Diffuser			FD11-95 Flush Diffuser
	2 Ends Open	1 Side & 2 Ends Open	All Ends & Sides Open		2 Ends Open	1 Side & 2 Ends Open	All Ends & Sides Open	
800	0.15	0.13	0.11	0.11	---	---	---	---
1000	0.19	0.16	0.14	0.14	---	---	---	---
1200	0.25	0.20	0.17	0.17	---	---	---	---
1400	0.33	0.26	0.20	0.20	---	---	---	---
1600	0.43	0.32	0.20	0.24	---	---	---	---
1800	0.56	0.40	0.30	0.30	0.13	0.11	0.09	0.09
2000	0.73	0.50	0.36	0.36	0.15	0.13	0.11	0.10
2200	0.95	0.63	0.44	0.44	0.18	0.15	0.12	0.12
2400	---	----	---	---	0.21	0.18	0.15	0.14
2600	---	----	---	---	0.24	0.21	0.18	0.17
2800	---	----	---	---	0.27	0.24	0.21	0.20
3000	---	----	---	---	0.32	0.29	0.25	0.25
3200	---	----	---	---	0.41	0.37	0.32	0.31
3400	---	----	---	---	0.50	0.45	0.39	0.37
3600	---	----	---	---	0.61	0.54	0.48	0.44

### CEILING DIFFUSER AIR THROW DATA

Air Volume - cfm	<sup>1</sup> Effective Throw - ft.	
	RTD9-65	FD9-65
800	10 - 17	14 - 18
1000	10 - 17	15 - 20
1200	11 - 18	16 - 22
1400	12 - 19	17 - 24
1600	12 - 20	18 - 25
1800	13 - 21	20 - 28
2000	14 - 23	21 - 29
2200	16 - 25	22 - 30
Model No.	RTD11-95	FD11-95
2600	24 - 29	19 - 24
2800	25 - 30	20 - 28
3000	27 - 33	21 - 29
3200	28 - 35	22 - 29
3400	30 - 37	22 - 30
3600	25 - 33	22 - 24

<sup>1</sup> Effective throw based on terminal velocities of 75 ft. per minute.

## OUTDOOR SOUND DATA

1 Unit Model No.	Octave Band Sound Power Levels dBA, re 10 <sup>-12</sup> Watts - Center Frequency - HZ							Sound Rating Number (dB)
	125	250	500	1000	2000	4000	8000	
024, 030, 036 and 048	63	66	70	71	68	62	53	75
060 and 072	67	72	77	76	73	68	61	82
090	66	71	73	74	70	65	57	79

NOTE - The octave sound power data shown does not include tonal correction.

<sup>1</sup> Tested according to AHRI Standard 270-95 test conditions.

## ELECTRICAL DATA 2 - 2.5 TON

DIRECT DRIVE BLOWER		KGA024S	KGA030S
1 Voltage - 60hz		208/230V - 1 Ph	
Compressor 1	Rated Load Amps	13.5	14.1
	Locked Rotor Amps	58.3	73
Outdoor Fan Motors (1)	Full Load Amps (total)	1.7	1.7
Service Outlet 115V GFI		15 Amps	15 Amps
Indoor Blower Motor	Horsepower	.25	.25
	Full Load Amps	1.8	1.8
2 Maximum Overcurrent Protection	Unit Only	30	35
3 Minimum Circuit Ampacity	Unit Only	21	22

## ELECTRICAL ACCESSORIES

Disconnect Kit	Standard Access	20W17	20W17
	Hinged Access	20W23	20W23

<sup>1</sup> Extremes of operating range are plus and minus 10% of line voltage.

<sup>2</sup> HACR type breaker or fuse.

<sup>3</sup> Refer to National or Canadian Electrical Code manual to determine wire, fuse and disconnect size requirements.

## ELECTRICAL DATA 3 TON

### KGA036S

1 Voltage - 60hz		208/230V - 1 Ph			208/230V - 3 Ph			460V - 3 Ph			575V - 3 Ph		
Compressor 1	Rated Load Amps	16.7			10.4			5.8			3.8		
	Locked Rotor Amps	79			73			38			36.5		
Outdoor Fan Motors (1)	Full Load Amps (total)	1.7			1.7			1.1			0.7		
Power Exhaust (1) 0.75 HP	Full Load Amps (total)	5			5			2.2			1.5		
Service Outlet 115V GFI		15 Amps			15 Amps			15 Amps			15 Amps		
Indoor Blower Motor	Horsepower	.5	1.5	.5	1.5	2	.5	1.5	2	.5	1.5	2	
	Full Load Amps	3.9	11	3.9	6.6	7.5	2	3	3.4	2	2.4	2.7	
2 Maximum Overcurrent Protection	Unit Only	40	50	25	30	30	15	15	15	15	15	15	
	with (1) 0.75 HP Power Exhaust	45	50	30	35	35	15	15	15	15	15	15	
3 Minimum Circuit Ampacity	Unit Only	27	34	19	22	23	11	12	12	8	8	9	
	with (1) 0.75 HP Power Exhaust	32	39	24	27	28	13	14	14	9	10	10	

## ELECTRICAL ACCESSORIES

Disconnect Kit	Standard Access	20W17	20W17	20W17	20W17	20W17	20W17	20W17	20W17
	Hinged Access	20W23	20W23	20W23	20W23	20W23	20W23	20W23	20W23

<sup>1</sup> Extremes of operating range are plus and minus 10% of line voltage.

<sup>2</sup> HACR type breaker or fuse.

<sup>3</sup> Refer to National or Canadian Electrical Code manual to determine wire, fuse and disconnect size requirements.

## ELECTRICAL DATA 4 TON

### KGA048S

<sup>1</sup> Voltage - 60hz		208/230V - 1 Ph			208/230V - 3 Ph			460V - 3 Ph			575V - 3 Ph		
<b>Compressor 1</b>	Rated Load Amps	21.8			13.7			6.2			4.8		
	Locked Rotor Amps	117			83.1			41			33		
<b>Outdoor Fan Motors (1)</b>	Full Load Amps (total)	1.7			1.7			1.1			0.7		
<b>Power Exhaust (1) 0.75 HP</b>	Full Load Amps (total)	5			5			2.2			1.5		
<b>Service Outlet 115V GFI</b>		15 Amps			15 Amps			15 Amps			15 Amps		
<b>Indoor Blower Motor</b>	Horsepower	.5	1.5	.5	1.5	2	.5	1.5	2	.5	1.5	2	
	Full Load Amps	3.9	11	3.9	6.6	7.5	2	3	3.4	2	2.4	2.7	
<b><sup>2</sup> Maximum Overcurrent Protection</b>	Unit Only	50	60	35	35	40	15	15	15	15	15	15	
	with (1) 0.75 HP Power Exhaust	50	60	40	40	45	15	20	20	15	15	15	
<b><sup>3</sup> Minimum Circuit Ampacity</b>	Unit Only	33	40	23	26	27	11	12	13	9	10	10	
	with (1) 0.75 HP Power Exhaust	38	45	28	31	32	14	15	15	11	11	11	

### ELECTRICAL ACCESSORIES

<b>Disconnect Kit</b>	Standard Access	<b>20W17</b>	<b>20W17</b>	<b>20W17</b>	<b>20W17</b>	<b>20W17</b>	<b>20W17</b>			<b>20W17</b>		
	Hinged Access	<b>20W23</b>	<b>20W23</b>	<b>20W23</b>	<b>20W23</b>	<b>20W23</b>	<b>20W23</b>			<b>20W23</b>		

<sup>1</sup> Extremes of operating range are plus and minus 10% of line voltage.

<sup>2</sup> HACR type breaker or fuse.

<sup>3</sup> Refer to National or Canadian Electrical Code manual to determine wire, fuse and disconnect size requirements.

## ELECTRICAL/ELECTRIC HEAT DATA

## 5 TON

### KGA060S

<sup>1</sup> Voltage - 60hz		208/230V - 1 Ph			208/230V - 3 Ph			460V - 3 Ph			575V - 3 Ph		
<b>Compressor 1</b>	Rated Load Amps	26.4			16			7.8			5.7		
	Locked Rotor Amps	134			110			52			38.9		
<b>Outdoor Fan Motors (1)</b>	Full Load Amps (total)	2.4			2.4			1.3			1		
<b>Power Exhaust (1) 0.75 HP</b>	Full Load Amps (total)	5			5			2.2			1.5		
<b>Service Outlet 115V GFI</b>		15 Amps			15 Amps			15 Amps			15 Amps		
<b>Indoor Blower Motor</b>	Horsepower	.75	1.5	.75	1.5	2	.75	1.5	2	.75	1.5	2	
	Full Load Amps	4.9	4.9	11	6.6	7.5	2.5	3	3.4	2.5	2.4	2.7	
<b><sup>2</sup> Maximum Overcurrent Protection</b>	Unit Only	60	70	40	45	45	20	20	20	15	15	15	
	with (1) 0.75 HP Power Exhaust	70	70	45	50	50	20	20	20	15	15	15	
<b><sup>3</sup> Minimum Circuit Ampacity</b>	Unit Only	41	47	28	29	30	14	15	15	11	11	11	
	with (1) 0.75 HP Power Exhaust	46	52	33	34	35	16	17	17	13	13	13	

### ELECTRICAL ACCESSORIES

<b>Disconnect Kit</b>	Standard Access	<b>20W17</b>	<b>20W17</b>	<b>20W17</b>	<b>20W17</b>	<b>20W17</b>	<b>20W17</b>			<b>20W17</b>		
	Hinged Access	<b>20W23</b>	<b>20W23</b>	<b>20W23</b>	<b>20W23</b>	<b>20W23</b>	<b>20W23</b>			<b>20W23</b>		

<sup>1</sup> Extremes of operating range are plus and minus 10% of line voltage.

<sup>2</sup> HACR type breaker or fuse.

<sup>3</sup> Refer to National or Canadian Electrical Code manual to determine wire, fuse and disconnect size requirements.

**ELECTRICAL/ELECTRIC HEAT DATA****6 TON****KGA072S**

<sup>1</sup> Voltage - 60hz		208/230V - 3 Ph		460V - 3 Ph		575V - 3 Ph	
<b>Compressor 1</b>	Rated Load Amps	19		9.7		7.4	
	Locked Rotor Amps	123		62		50	
<b>Outdoor Fan Motors (1)</b>	Full Load Amps (total)	2.4		1.3		1	
<b>Power Exhaust (1) 0.75 HP</b>	Full Load Amps (total)	5		2.2		1.5	
<b>Service Outlet 115V GFI</b>		15 Amps		15 Amps		15 Amps	
<b>Indoor Blower Motor</b>	Horsepower	1.5	2	1.5	2	1.5	2
	Full Load Amps	6.6	7.5	3	3.4	2.4	2.7
<sup>2</sup> <b>Maximum Overcurrent Protection</b>	Unit Only	50	50	25	25	20	20
	with (1) 0.75 HP Power Exhaust	50	50	25	25	20	20
<sup>3</sup> <b>Minimum Circuit Ampacity</b>	Unit Only	33	34	17	17	13	13
	with (1) 0.75 HP Power Exhaust	38	39	19	20	15	15

**ELECTRICAL ACCESSORIES**

<b>Disconnect Kit</b>	Standard Access	<b>20W20</b>	<b>20W20</b>	<b>20W20</b>	<b>20W20</b>
	Hinged Access	<b>20W26</b>	<b>20W26</b>	<b>20W26</b>	<b>20W26</b>

<sup>1</sup> Extremes of operating range are plus and minus 10% of line voltage.<sup>2</sup> HACR type breaker or fuse.<sup>3</sup> Refer to National or Canadian Electrical Code manual to determine wire, fuse and disconnect size requirements.**ELECTRICAL DATA****7.5 TON****KGA090S**

<sup>1</sup> Voltage - 60hz		208/230V - 3 Ph			460V - 3 Ph			575V - 3 Ph		
<b>Compressor 1</b>	Rated Load Amps	25			12.2			9		
	Locked Rotor Amps	164			100			78		
<b>Outdoor Fan Motors (1)</b>	Full Load Amps (total)	2.4			1.3			1		
<b>Power Exhaust (1) 0.75 HP</b>	Full Load Amps (total)	5			2.2			1.5		
<b>Service Outlet 115V GFI</b>		15 Amps			15 Amps			15 Amps		
<b>Indoor Blower Motor</b>	Horsepower	1	2	3	1	2	3	1	2	3
	Full Load Amps	4.6	7.5	10.6	2.1	3.4	4.8	1.7	2.7	3.9
<sup>2</sup> <b>Maximum Overcurrent Protection</b>	Unit Only	60	60	60	30	30	30	20	20	25
	with (1) 0.75 HP Power Exhaust	60	70	70	30	30	35	20	25	25
<sup>3</sup> <b>Minimum Circuit Ampacity</b>	Unit Only	39	42	45	19	20	22	14	15	17
	with (1) 0.75 HP Power Exhaust	44	47	50	21	23	24	16	17	18

**ELECTRICAL ACCESSORIES**

<b>Disconnect Kit</b>	Standard Access	<b>20W18</b>	<b>20W18</b>	<b>20W19</b>	<b>20W18</b>	<b>20W18</b>
	Hinged Access	<b>20W24</b>	<b>20W24</b>	<b>20W25</b>	<b>20W24</b>	<b>20W24</b>

<sup>1</sup> Extremes of operating range are plus and minus 10% of line voltage.<sup>2</sup> HACR type breaker or fuse.<sup>3</sup> Refer to National or Canadian Electrical Code manual to determine wire, fuse and disconnect size requirements.

## UNIT CLEARANCES - INCHES (MM)

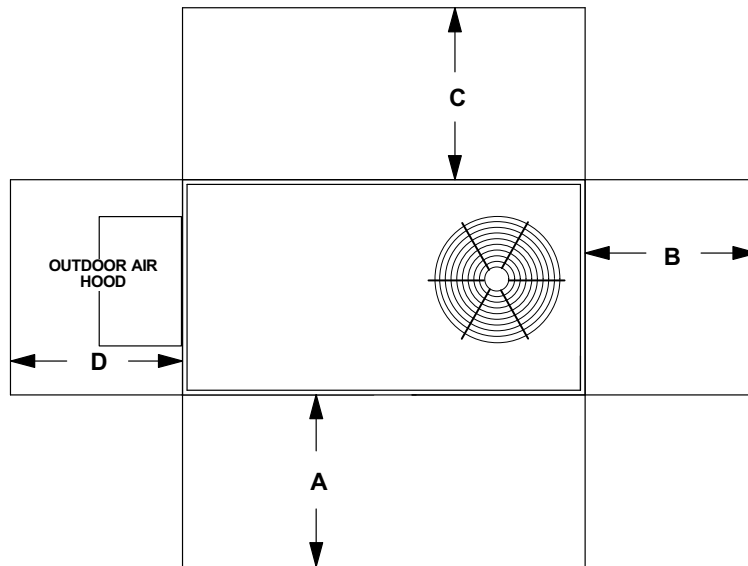

<sup>1</sup> Unit Clearance	A		B		C		D		Top Clearance
	in.	mm	in.	mm	in.	mm	in.	mm	
<b>Service Clearance</b>	48	1219	36	914	36	914	36	914	<b>Unobstructed</b>
<b>Clearance to Combustibles</b>	36	914	1	25	1	25	1	25	
<b>Minimum Operation Clearance</b>	36	914	36	914	36	914	36	914	

NOTE - Entire perimeter of unit base requires support when elevated above the mounting surface.

<sup>1</sup> **Service Clearance** - Required for removal of serviceable parts.

**Clearance to Combustibles** - Required clearance to combustible material.

**Minimum Operation Clearance** - Required clearance for proper unit operation.

## WEIGHT DATA

Model Number	Net				Shipping			
	Base		Max.		Base		Max.	
	lbs.	kg	lbs.	kg	lbs.	kg	lbs.	kg
024S	531	241	631	286	591	268	700	318
030S	533	242	633	287	593	269	702	318
036S	534	242	634	288	594	269	703	319
048S	571	259	682	309	631	286	751	341
060S	601	273	712	323	661	300	781	354
072S	700	318	798	362	760	345	870	395
090S	805	365	905	411	865	392	975	442

Base Unit - The unit with standard heat exchanger NO OPTIONS.

Max. Unit - The unit with ALL OPTIONS Installed. (High Input Heat Exchanger, Economizer, etc.)

## OPTIONS / ACCESSORIES

			Shipping Weights	
			lbs.	kg
<b>ECONOMIZER / OUTDOOR AIR</b>				
<b>Economizer</b>				
Economizer, Includes Outdoor Air Hood and Barometric Relief Dampers with Hood	T1ECON30A-1		123	56
	T1ECON30N-1		142	65
<b>OUTDOOR AIR</b>				
<b>Outdoor Air Dampers</b>				
Outdoor Air Damper Motorized Kit	T1DAMP11A-1		25	12
	T1DAMP11N-1		29	14
Damper Section Manual	T1DAMP21AN1		18	9
<b>Power Exhaust</b>				
Standard Static	T1PWRE10A-1		35	17
	T1PWRE10N-1		39	19
<b>GAS HEAT</b>				
	Medium Input		8	4
	High Input		19	9
<b>ROOF CURBS - DOWNFLOW</b>				
<b>Cliplock</b>				
8 in. height	T1CURB23AN1		78	35
	K1CURB23AP1		83	38
14 in. height	T1CURB20AN1		96	44
	K1CURB20AP1		101	46
18 in. height	T1CURB21AN1		108	49
	K1CURB21AP1		113	51
24 in. height	T1CURB22AN1		126	57
	K1CURB22AP1		131	59
<b>Hinged</b>				
8 in. height	T1CURB30AN1		78	35
	K1CURB30AP1		83	38
18 in. height	T1CURB32AN1		108	49
	K1CURB32AP1		113	51
24 in. height	T1CURB33AN1		126	57
	K1CURB33AP1		131	59
<b>Standard</b>				
14 in. height	T1CURB10AN1		96	44
	K1CURB10AP1		101	46
<b>CEILING DIFFUSERS</b>				
Step-Down	RTD9-65		67	30
	RTD11-95		88	40
Flush	FD9-65		37	17
	FD11-95		75	34
Transitions (Supply and Return)	T1TRAN10AN1		22	10
	T1TRAN20N-1		21	10

# DIMENSIONS - INCHES (MM)

Model No.	CORNER WEIGHTS										CENTER OF GRAVITY													
	AA		BB		CC		DD		EE				FF											
	Base	Max.	Base	Max.	Base	Max.	Base	Max.	Base	Max.	Base	Max.	Base	Max.										
	lbs. kg	lbs. kg	lbs. kg	lbs. kg	lbs. kg	lbs. kg	lbs. kg	lbs. kg	in. mm	in. mm	in. mm	in. mm	in. mm	in. mm										
024	92	42	113	52	112	51	128	58	180	82	207	94	148	67	183	83	38-1/2	978	40	1016	18	457	18	457
030	92	42	114	52	112	51	129	58	180	82	207	94	149	68	183	83	38-1/2	978	40	1016	18	457	18	457
036	92	42	114	52	112	51	129	59	181	82	208	94	149	68	184	83	38-1/2	978	40	1016	18	457	18	457
048	99	45	123	56	120	55	139	63	193	88	223	102	159	72	197	90	38-1/2	978	40	1016	18	457	18	457
060	104	47	128	58	126	57	145	66	203	92	233	106	167	76	206	94	38-1/2	978	40	1016	18	457	18	457
072	121	55	143	65	147	67	162	74	237	108	261	119	195	89	231	105	38-1/2	978	40	1016	18	457	18	457
090	168	76	195	88	183	83	212	96	227	103	263	119	203	95	241	109	47	1194	47	1194	21	533	21	533

Base Unit - The unit with standard heat exchanger NO OPTIONS.

Max. Unit - The unit with ALL OPTIONS Installed. (High Input Heat Exchanger, Economizer, etc.)

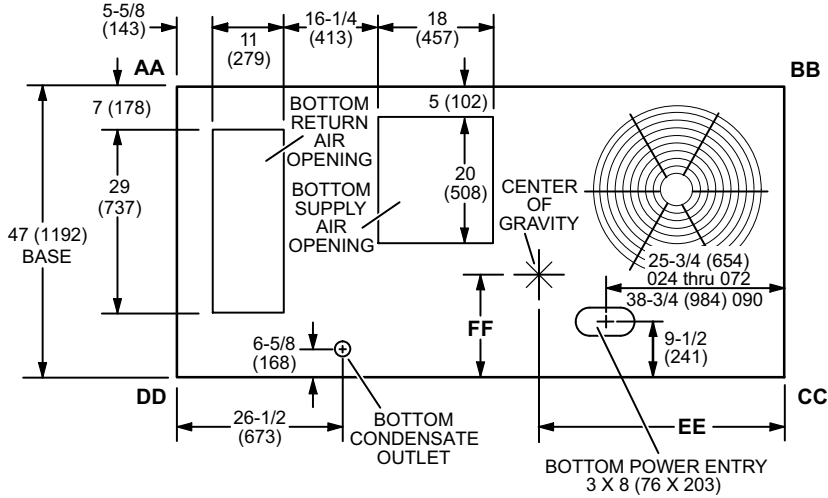

**TOP VIEW (Base)**

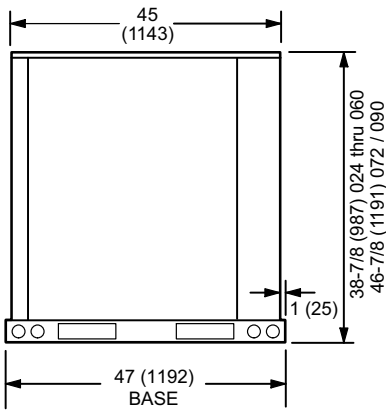

**END VIEW**

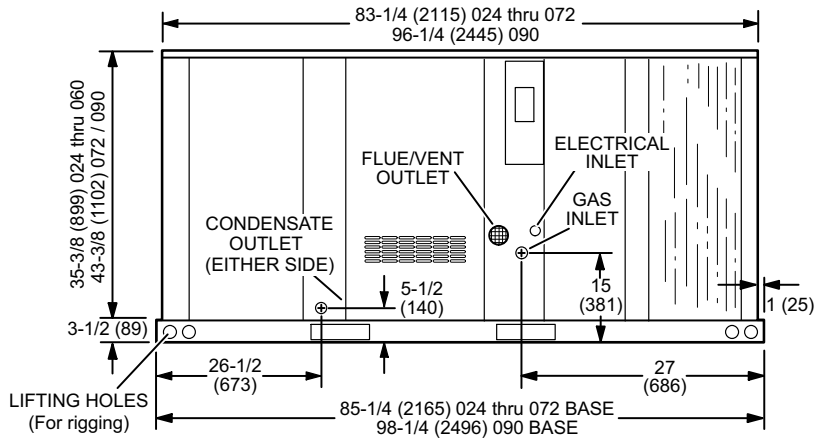

**SIDE VIEW**

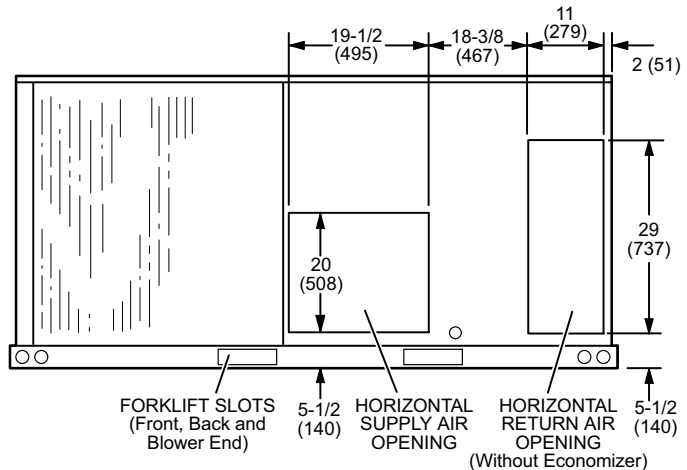

**BACK VIEW**

## ACCESSORY DIMENSIONS - INCHES (MM)

### OUTDOOR AIR HOOD DETAIL FOR OPTIONAL ECONOMIZER AND BAROMETRIC RELIEF DAMPERS (Downflow Applications)

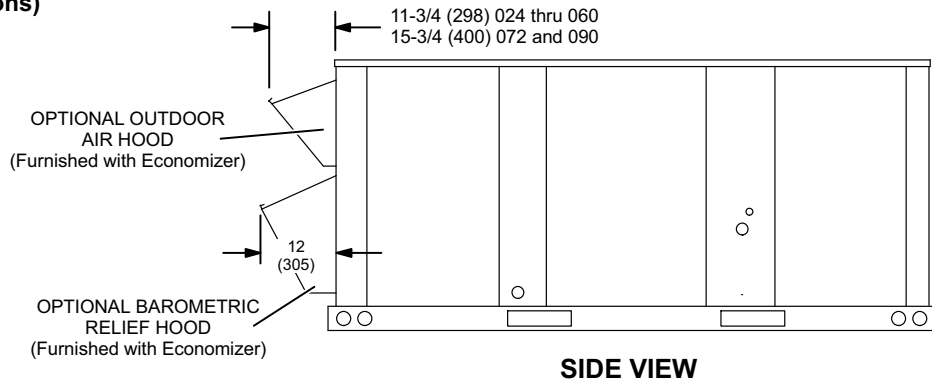

### OUTDOOR AIR HOOD FOR ECONOMIZER (Furnished)

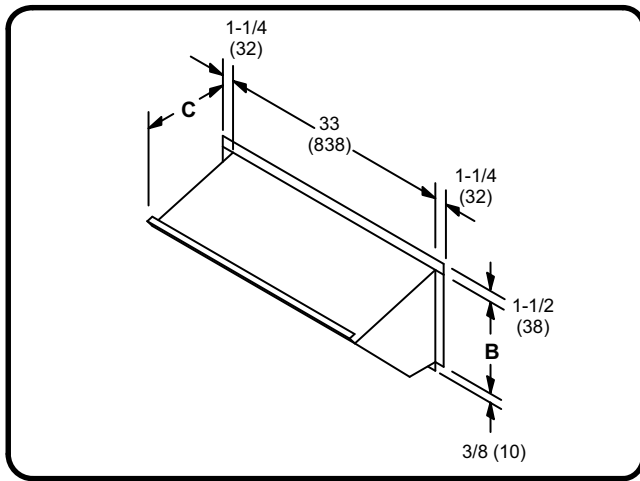

### BAROMETRIC RELIEF HOOD FOR ECONOMIZER (Furnished)

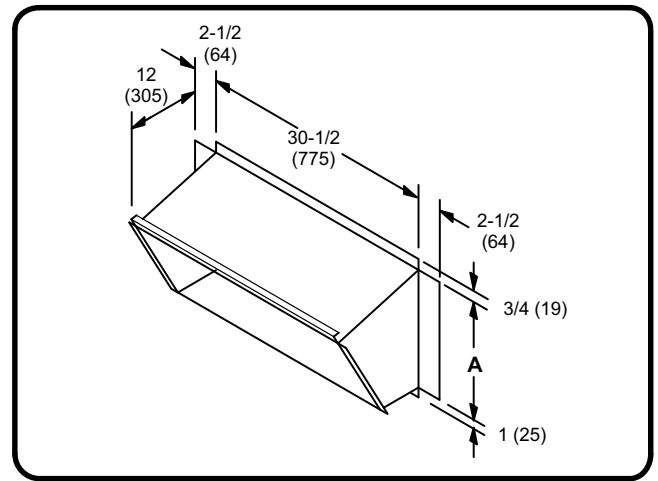

Model No.	A		B		C	
	in.	mm	in.	mm	in.	mm
024, 030, 036, 048, 060	19-1/4	489	13	330	11-3/4	298
072, 090	23-1/4	591	17	432	15-3/4	400

### OUTDOOR AIR DAMPER HOOD DETAIL FOR OPTIONAL MANUAL OR MOTORIZED OUTDOOR AIR DAMPERS (Downflow or Horizontal Applications)

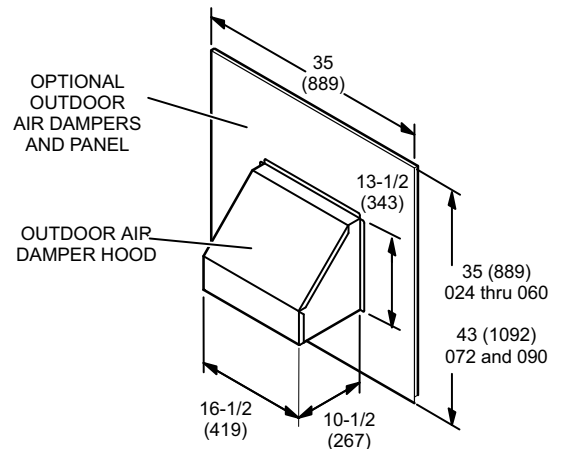
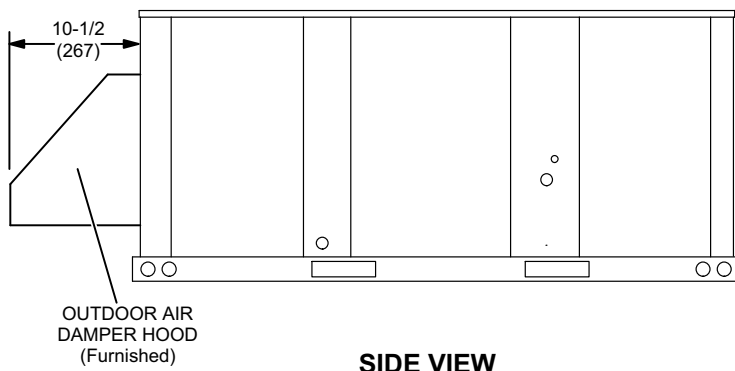

# ACCESSORY DIMENSIONS - INCHES (MM)

## OUTDOOR AIR HOOD DETAIL WITH OPTIONAL ECONOMIZER AND BAROMETRIC RELIEF DAMPERS (Horizontal Applications)

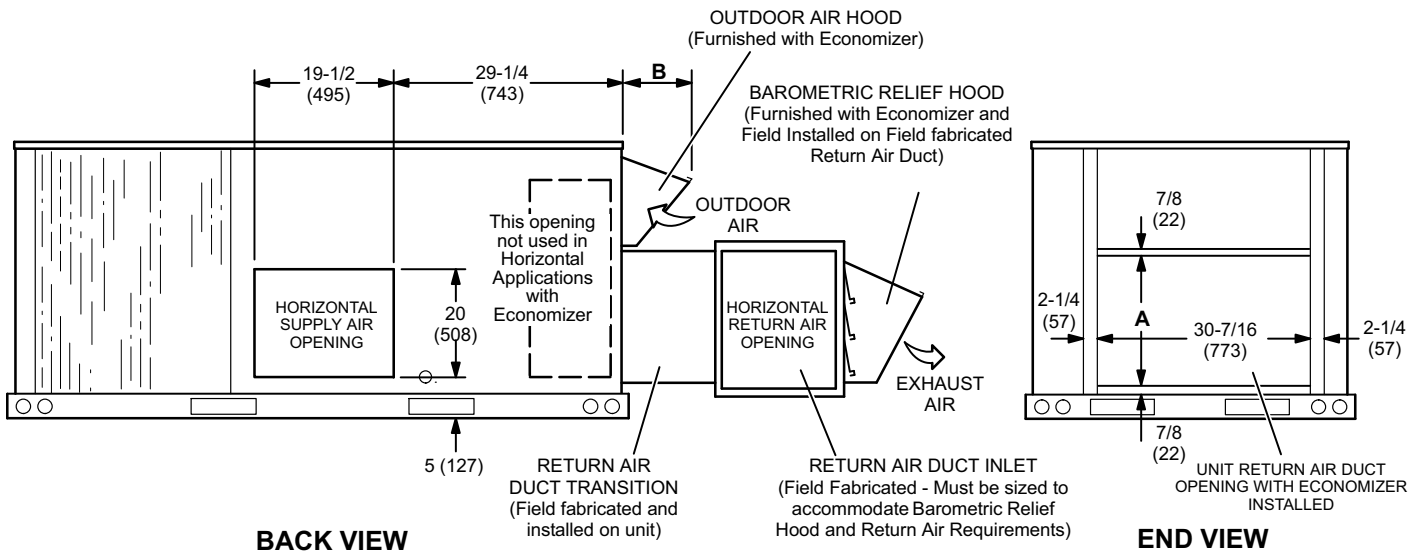
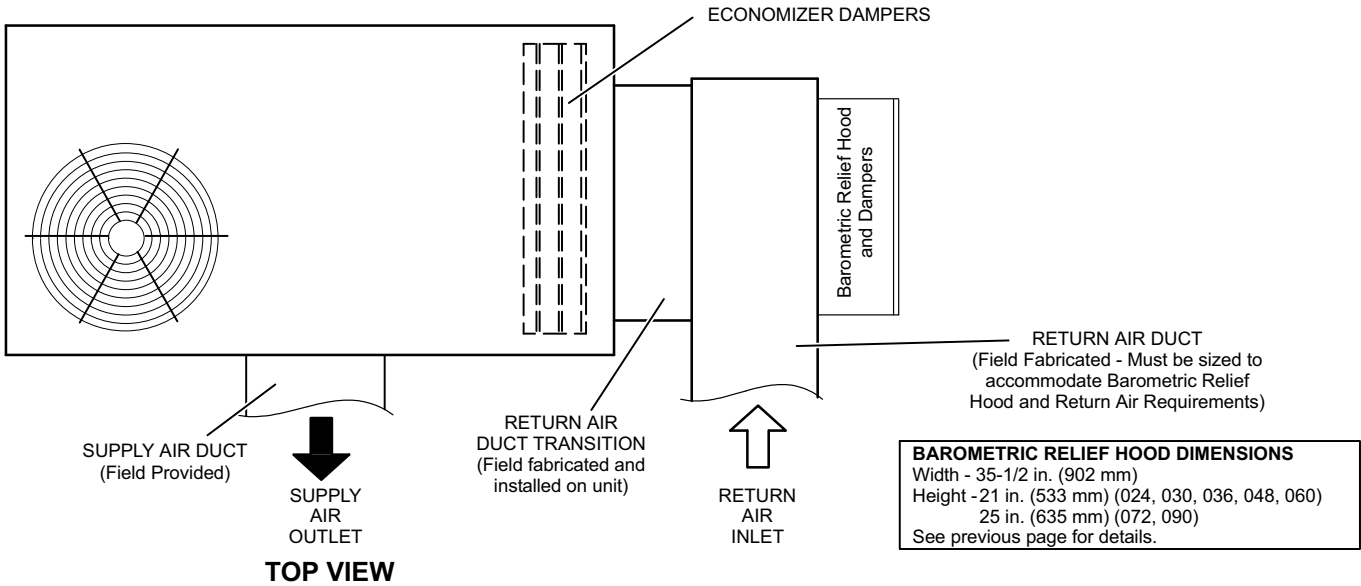

**NOTE** - Return Air Duct and Transition must be supported.

Model No.	A		B	
	in.	mm	in.	mm
<b>024, 030, 036, 048, 060</b>	18-3/4	476	11-3/4	298
<b>072, 090</b>	22-1/2	572	15-3/4	400

# ACCESSORY DIMENSIONS - INCHES (MM)

## CLIPLOCK 1000 ROOF CURBS - DOUBLE DUCT OPENING

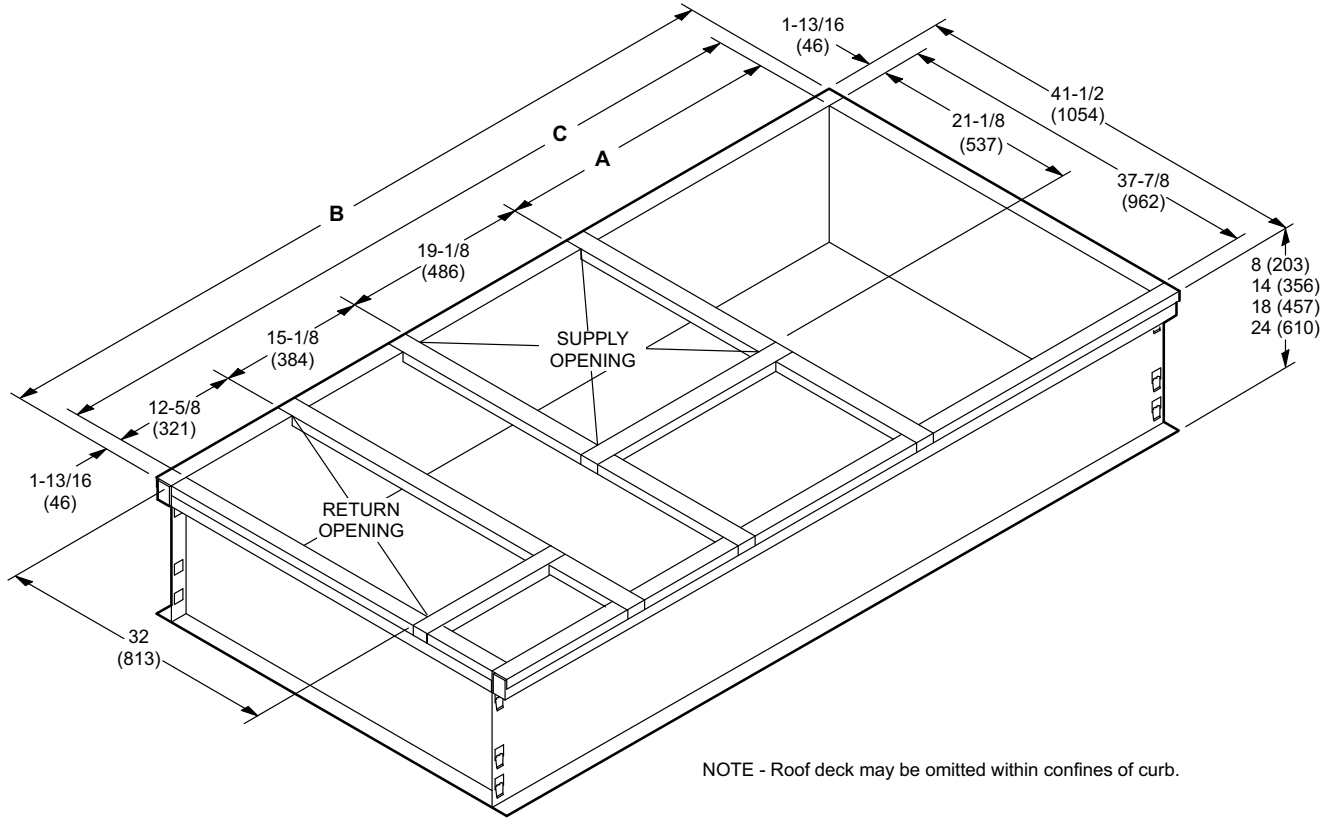

NOTE - Roof deck may be omitted within confines of curb.

### TYPICAL FLASHING DETAIL FOR ROOF CURB

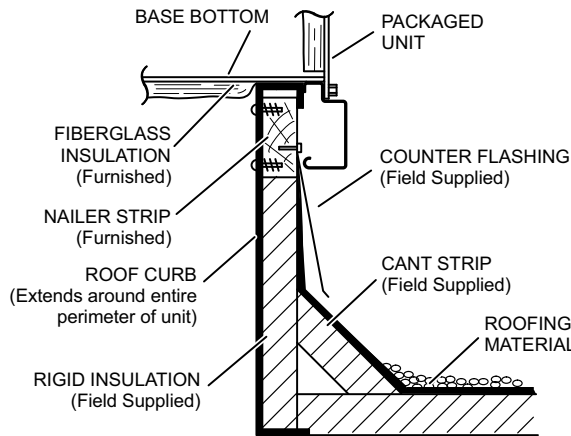

### DETAIL ROOF CURB

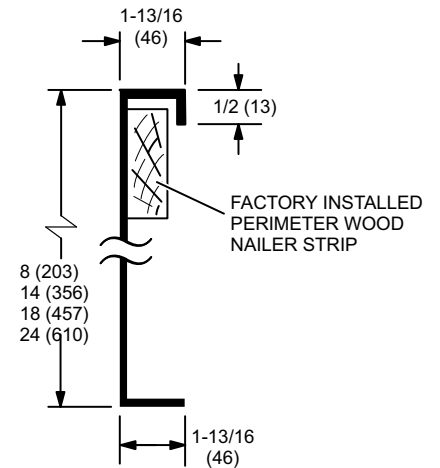

Model No.	A		B		C	
	in.	mm	in.	mm	in.	mm
024, 030, 036, 048, 060, 072, <sup>1</sup> 090	29-1/4	743	79-3/4	2026	76-1/8	1934
090	42-1/4	1073	92-3/4	2356	89-1/8	2264

<sup>1</sup> 090 models can be used on smaller 79-3/4 in. (2026 mm) roof curbs (not full perimeter) with 15-3/4 in. (400 mm) overhang at condenser end of unit. See dimension drawing on page 38.

# ACCESSORY DIMENSIONS - INCHES (MM)

## HINGED ROOF CURBS - DOUBLE DUCT OPENING

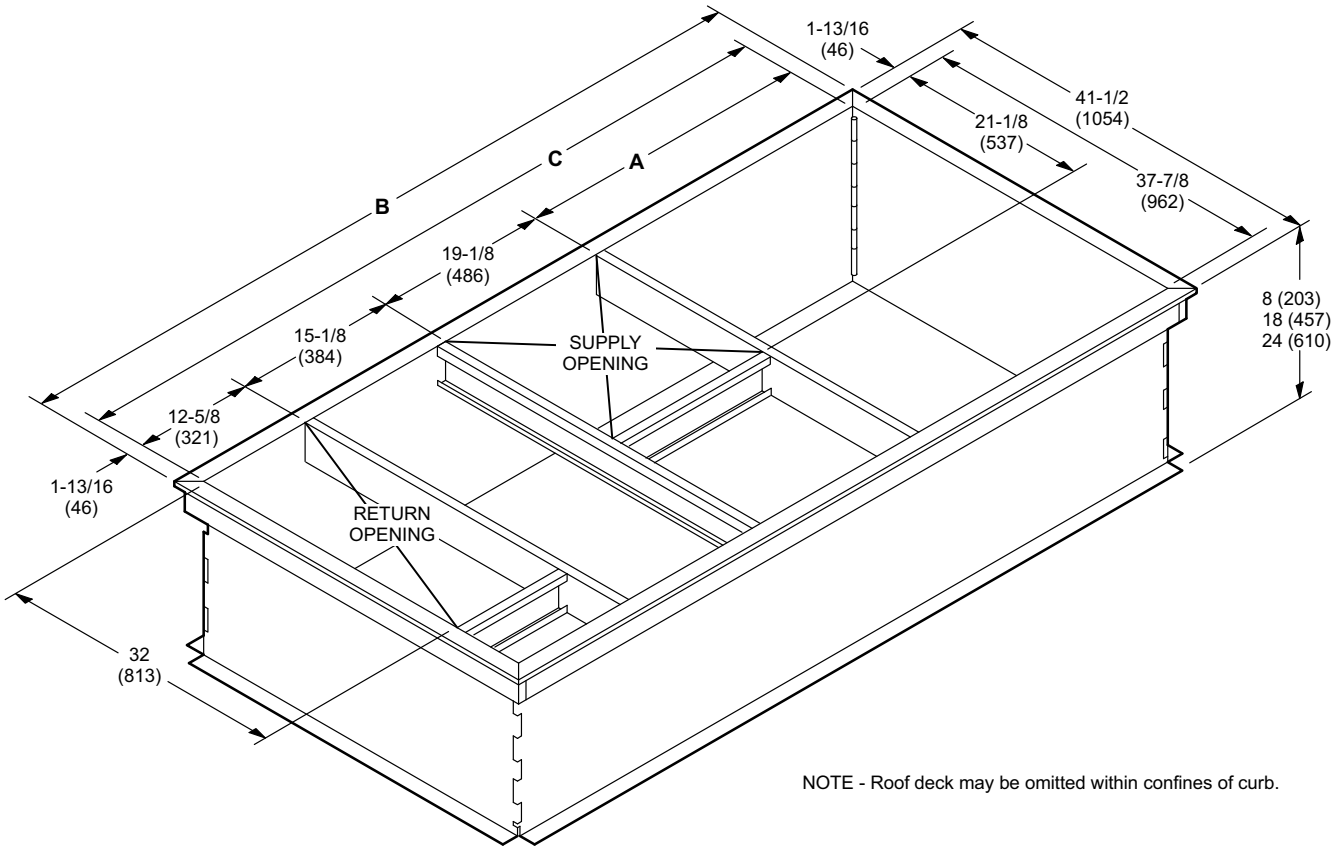

NOTE - Roof deck may be omitted within confines of curb.

### TYPICAL FLASHING DETAIL FOR ROOF CURB

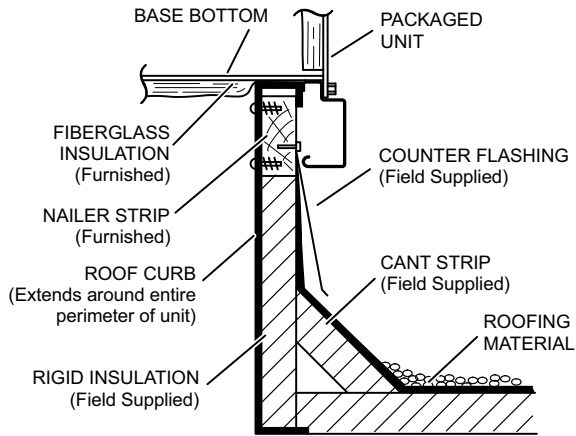

### DETAIL ROOF CURB

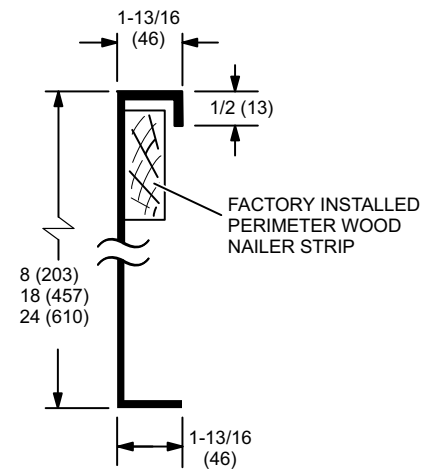

Model No.	A		B		C	
	in.	mm	in.	mm	in.	mm
024, 030, 036, 048, 060, 072, <sup>1</sup> 090	29-1/4	743	79-3/4	2026	76-1/8	1934
090	42-1/4	1073	92-3/4	2356	89-1/8	2264

<sup>1</sup> 090 models can be used on smaller 79-3/4 in. (2026 mm) roof curbs (not full perimeter) with 15-3/4 in. (400 mm) overhang at condenser end of unit. See dimension drawing on page 38.

# ACCESSORY DIMENSIONS - INCHES (MM)

## STANDARD ROOF CURBS - DOUBLE DUCT OPENING

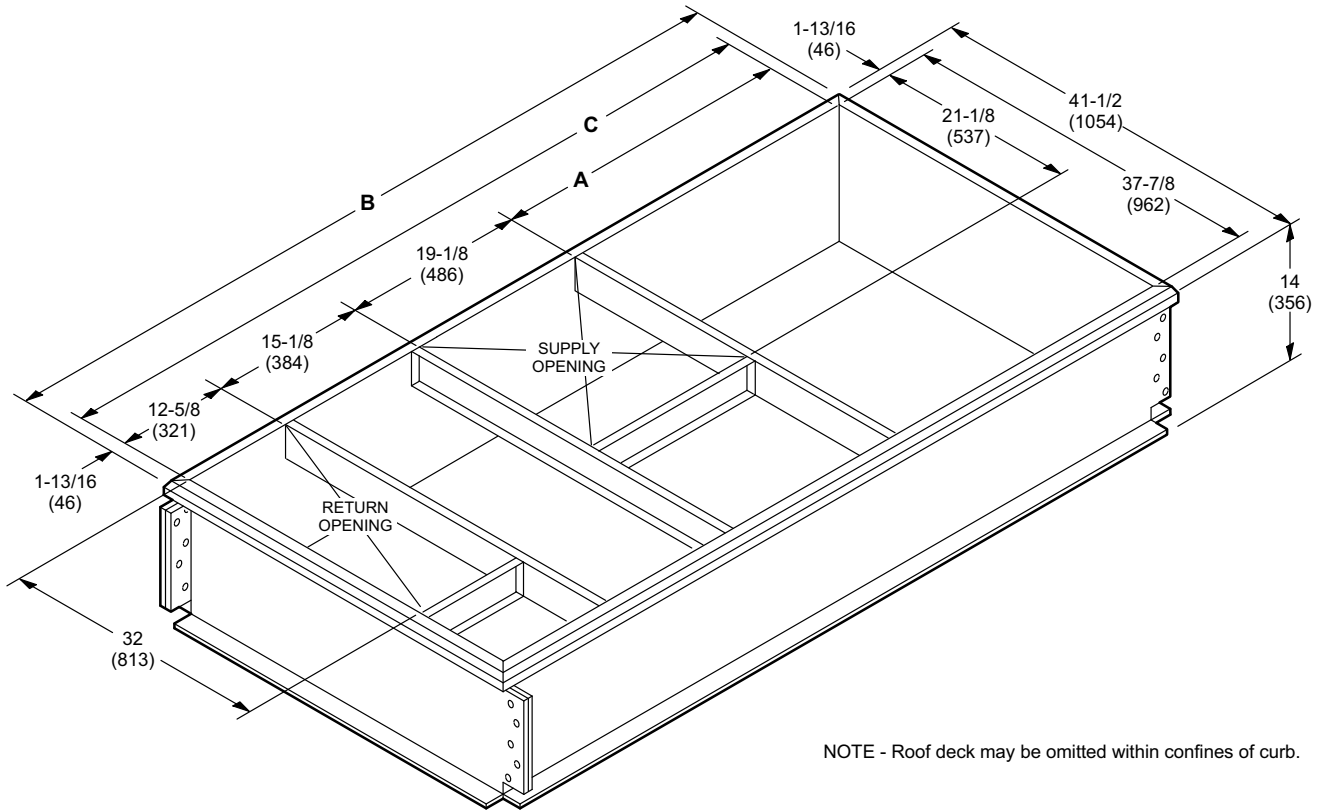

### TYPICAL FLASHING DETAIL FOR ROOF CURB

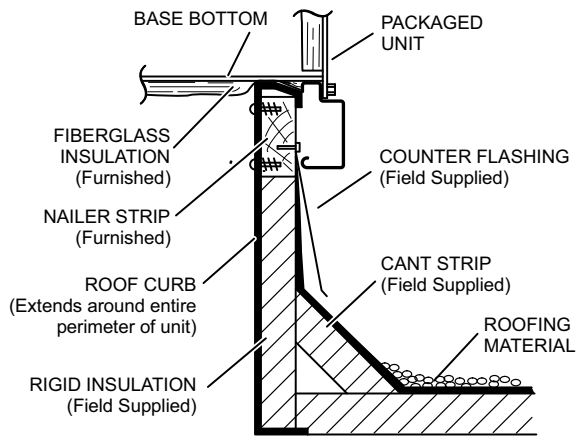

### DETAIL ROOF CURB

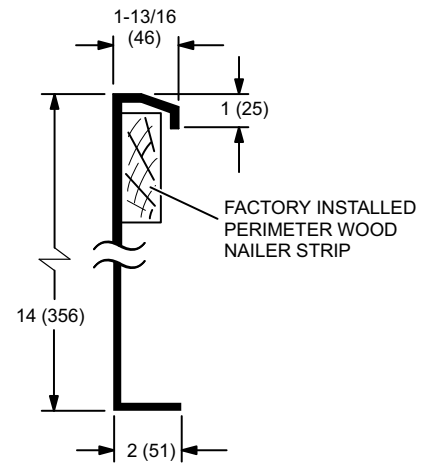

Model No.	A		B		C	
	in.	mm	in.	mm	in.	mm
024, 030, 036, 048, 060, 072, <sup>1</sup> 090	29-1/4	743	79-3/4	2026	76-1/8	1934
090	42-1/4	1073	92-3/4	2356	89-1/8	2264

<sup>1</sup> 090 models can be used on smaller 79-3/4 in. (2026 mm) roof curbs (not full perimeter) with 15-3/4 in. (400 mm) overhang at condenser end of unit. See dimension drawing on page 38.

**ACCESSORY DIMENSIONS - INCHES (MM)**

**090 MODELS - SHOWING OVERHANG ON SMALLER 79-3/4 INCH LENGTH ROOF CURBS  
(Not Full Perimeter)**

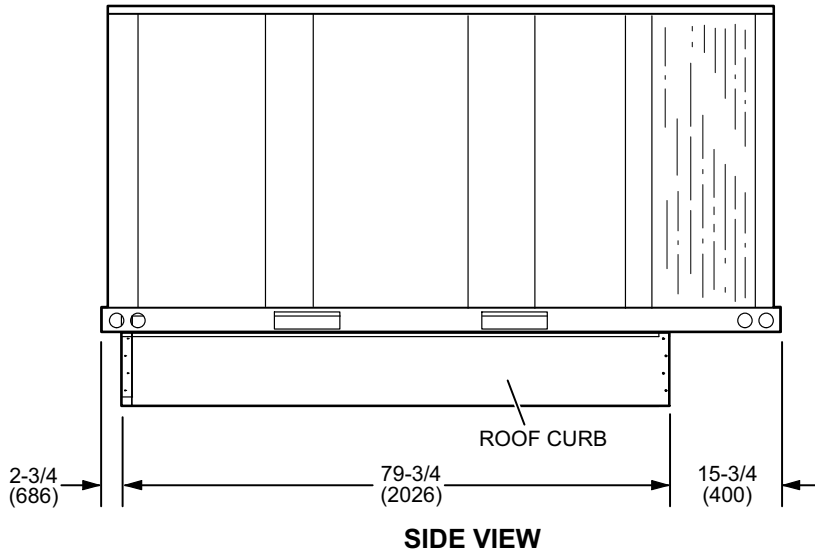

**TRANSITIONS**

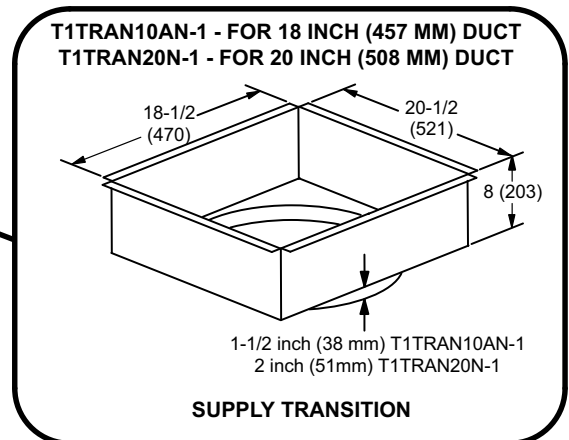
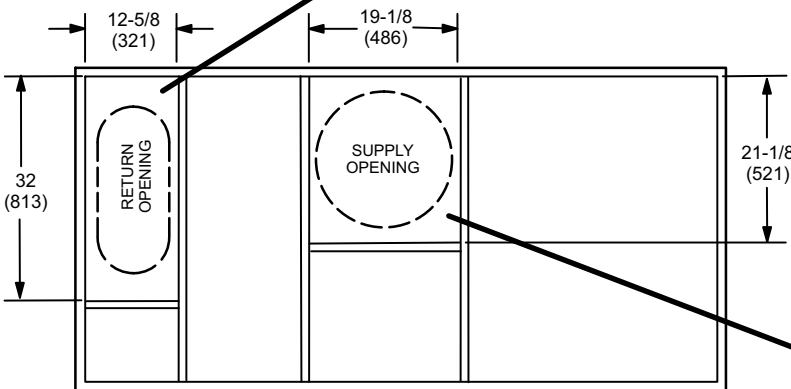
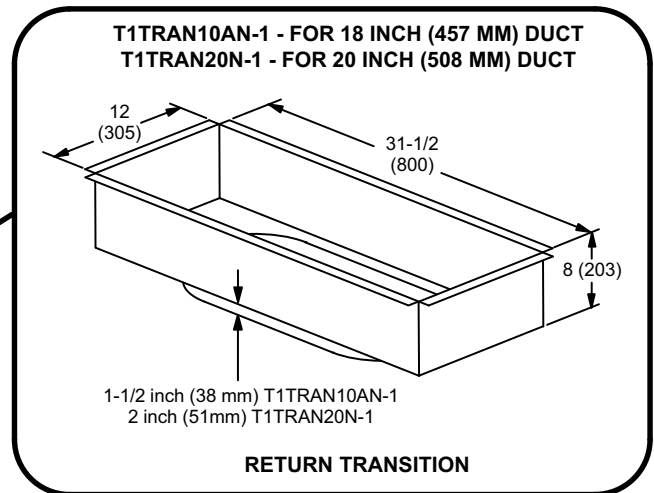

## ACCESSORY DIMENSIONS - INCHES (MM)

### COMBINATION CEILING SUPPLY AND RETURN DIFFUSERS

#### STEP-DOWN CEILING DIFFUSER

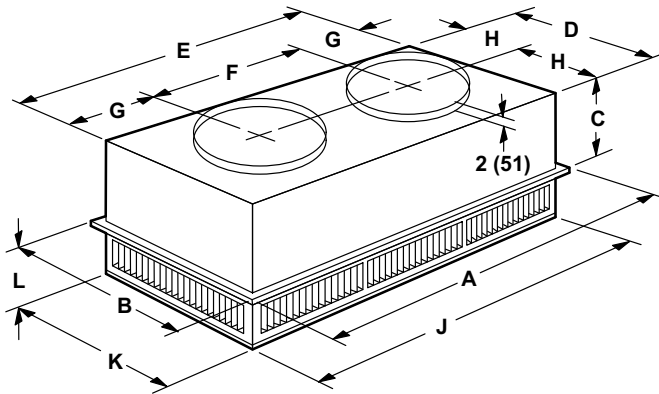

Model Number		RTD9-65	RTD11-95
A	in.	47-5/8	47-5/8
	mm	1159	1159
B	in.	23-5/8	29-5/8
	mm	600	752
C	in.	11-3/8	14-3/8
	mm	289	365
D	in.	21-1/2	27-1/2
	mm	546	699
E	in.	45-1/2	45-1/2
	mm	1156	1158
F	in.	22-1/2	22-1/2
	mm	572	572
G	in.	11-1/2	11-1/2
	mm	292	292
H	in.	10-3/4	13-3/4
	mm	273	349
J	in.	45-1/2	45-1/2
	mm	1156	1156
K	in.	21-1/2	27-1/2
	mm	546	699
L	in.	7-1/8	8-1/8
	mm	181	206
Duct Size	in.	18 round	20 round
	mm	457 round	508 round

#### FLUSH CEILING DIFFUSER

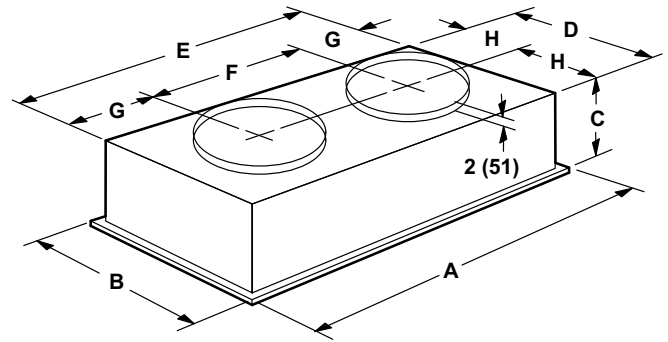

Model Number		FD9-65	FD11-95
A	in.	47-5/8	47-5/8
	mm	1159	1159
B	in.	23-5/8	29-5/8
	mm	600	752
C	in.	13-1/2	16-5/8
	mm	343	422
D	in.	21	27
	mm	533	686
E	in.	45	45
	mm	1143	1143
F	in.	22-1/2	22-1/2
	mm	572	572
G	in.	11-1/4	11-1/4
	mm	286	286
H	in.	10-1/2	13-1/2
	mm	267	343
Duct Size	in.	18 round	20 round
	mm	457 round	508 round

## REVISIONS

Sections	Description of Change
Options/Accessories	Drive Kits changed to Factory Installed.
Expanded ratings	Updated table for 090



VERIFIED  
ENERGY  
PERFORMANCE



VERIFIE  
RENDEMENT  
ENERGETIQUE



**ALLIED**  
Commercial

NOTE - Due to our ongoing commitment to quality, Specifications, Ratings and Dimensions subject to change without notice and without incurring liability. Improper installation, adjustment, alteration, service or maintenance can cause property damage or personal injury. Installation and service must be performed by a qualified installer and servicing agency.

©2009 Allied Air Enterprises